



**CPT® 12/14  
HIP SYSTEM**



**Surgical  
Technique for  
Primary Hip  
Arthroplasty**



**zimmer**  
*Confidence in your hands®*





# PRIMARY SURGICAL TECHNIQUE FOR THE CPT 12/14 COLLARLESS POLISHED TAPER HIP PROSTHESIS

## DEVELOPED IN CONJUNCTION WITH:

Claudio Castelli, M.D.  
Associate professor  
Director of Department of Orthopedic Surgery  
Joined Hospitals of Bergano, Italy

Clive P. Duncan, M.D., FRCSC  
Professor and Head  
Department of Orthopaedics  
UBC and VHHSC  
Vancouver, British Columbia, Canada

Adrian S. Graff-Radford, M.D., FACS  
Director Joint Replacement Service  
Desert Orthopaedic Center  
Rancho Mirage, California, U.S.A.

Donald W. Howie, Ph.D., F.R.A.C.S.  
Professor of Orthopaedics & Trauma  
University of Adelaide  
Australia

Peter McLardy-Smith, M.A., F.R.C.S.  
Specialist Hip & Knee Surgery Service  
Nuffield Orthopaedic Centre  
Oxford, England

Robert Middleton, M.A., F.R.C.S. (orth)  
Bournemouth Nuffield Hospital  
Bournemouth, England

Marc Philippon, M.D.  
Director of Sports Medicine/Hip Disorders  
Clinical Assistant Professor  
University of Pittsburgh  
Department of Orthopedic Surgery  
Pittsburgh, Pennsylvania, U.S.A.

## CONTENTS

INTRODUCTION .....	2
DESIGN PHILOSOPHY .....	3
10 QUICK STEPS FOR PRIMARY IMPLANTATION .....	4
PREOPERATIVE PLANNING .....	6
SURGICAL TECHNIQUE .....	8
Approach .....	8
Determination of Leg Length .....	8
Osteotomy of the Femoral Neck .....	10
Preparation of the Acetabulum .....	11
Preparation of the Femoral Canal .....	11
Trial Reduction .....	13
Component Implantation .....	15
Wound Closure .....	21





## INTRODUCTION

Collarless, polished tapered stems have been proven successful during more than 25 years of clinical use.<sup>1-4,8</sup> The CPT Hip System has continued this tradition of success since its introduction more than a decade ago.<sup>1,4,5,8</sup> The cobalt-chromium CPT Stem has been available in the United States since the early 1990s and has an excellent history of clinical results.<sup>1</sup> The 12/14 system provides improved kinematic function by offering up to three offsets for each stem body size. Zimmer utilizes the strength of cobalt-chromium to engineer offset designs that allow the surgeon to change from standard offset to extended offset to extra-extended offset without the need to rerasp. The collarless design also greatly simplifies leg length adjustments.

The CPT Hip System is a complete offering that encompasses two small stems, six primary sizes, and seven long stems. Two of the six primary sizes are available with standard and extended offsets, and the other four primary stems are available with standard, extended, and extra-extended offsets. Since they were first introduced, the shape of the standard-length stems within the cement mantle has been retained. The 12/14 taper at the head/neck interface enables a wide selection of femoral head/stem combinations and the optimized neck geometry enhances range of motion.

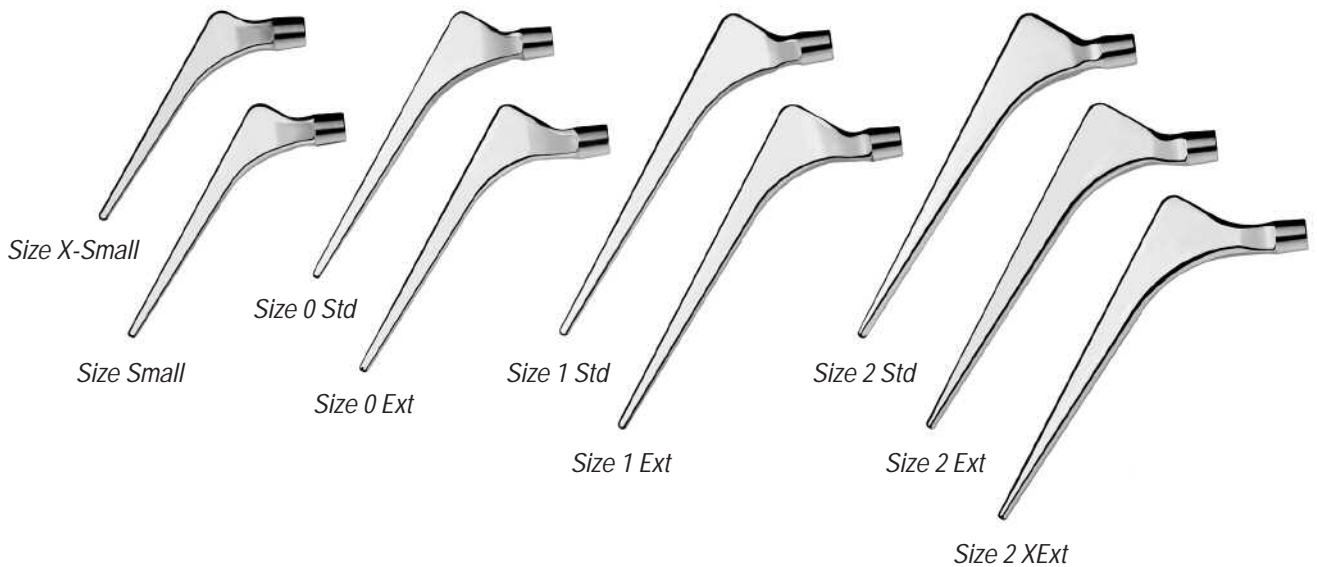

## DESIGN PHILOSOPHY

The *CPT* Hip Prosthesis has a collarless, highly polished, double-taper design. The philosophy was developed based on the three fundamental engineering principles represented by these key design features, and the properties of PMMA bone cement. Bone cement is stronger in compression than tension or shear and is a viscoelastic material which, under a constant load, deforms over time.<sup>6,7</sup> The *CPT* design helps to ensure that the prosthesis remains firmly seated as the cement deforms. The polished, tapered design optimizes the transfer of compressive forces to the cement rather than shear forces. The double taper wedges solidly in the bone cement mantle as the stem stabilizes.

Controlled subsidence in the first year is expected to occur, but after stabilization, subsidence is minimal. The polished surface allows the subsidence with minimal resistance or friction. The collarless feature allows subsidence and stabilization to occur without the physical constraint of a collar. Micromotion and subsidence have been shown to occur in total hip arthroplasty; therefore, the fact that these aspects are integrated into the design philosophy supports the outstanding clinical and radiographic results of the *CPT* Stem.<sup>1-4</sup>

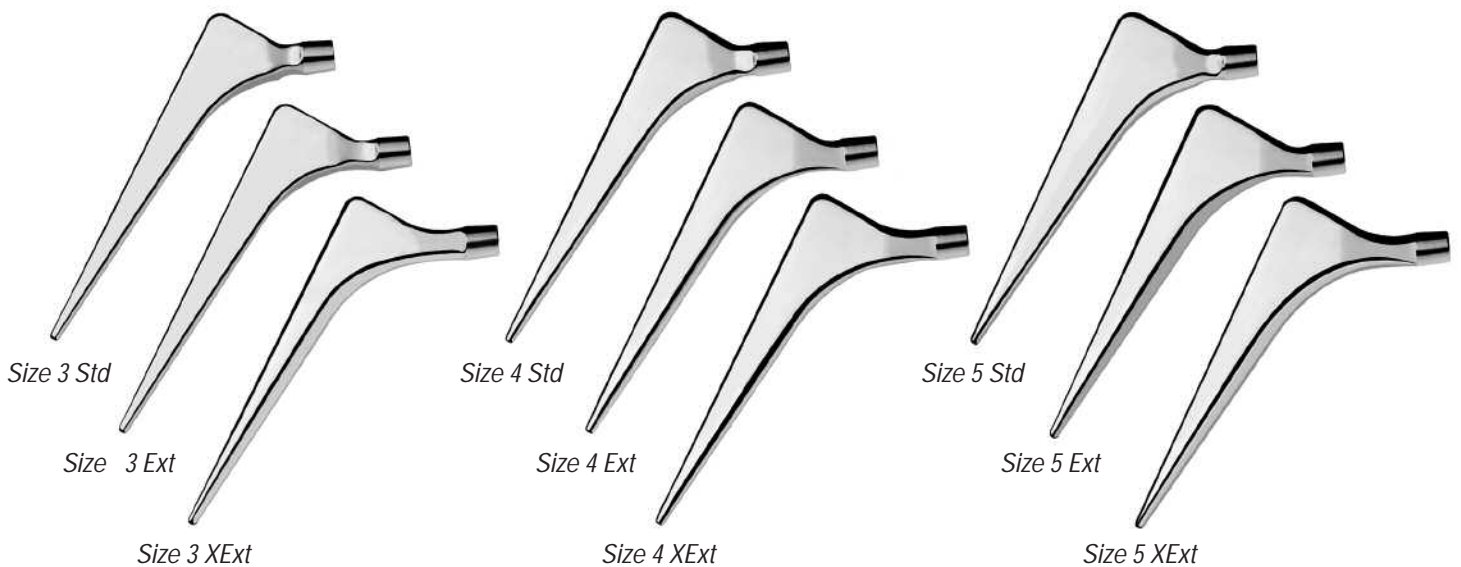

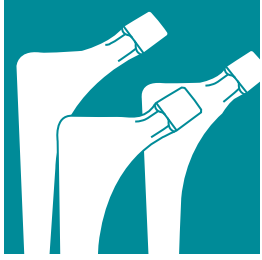

## 10 QUICK STEPS FOR PRIMARY IMPLANTATION

### 1 PREOPERATIVE PLANNING

Template to provide a basis for judging appropriate leg length and offset targets to achieve during surgery.



### 2 APPROACH

Expose the hip joint using your approach of choice.

### 3 DETERMINE LEG LENGTH

Before dislocating the hip, obtain a baseline measurement of leg length using your preferred method.

### 4 OSTEOTOMY OF THE FEMORAL NECK

Perform the femoral neck osteotomy.

An advantage of the CPT System is the ability to vary the neck osteotomy level. The osteotomy should be approximately 45 degrees to the femoral canal axis, and approximately 2cm above the lesser trochanter.

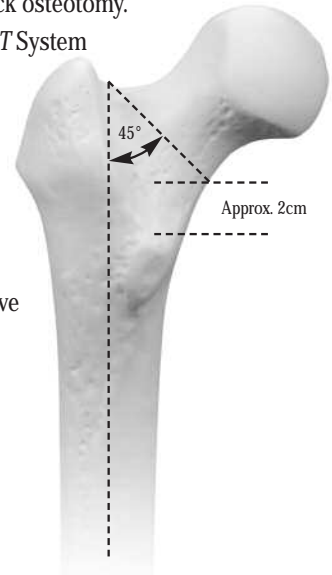

### 5 IMPLANTATION OF THE ACETABULAR COMPONENT

After resecting the femoral head, proceed to implantation of the acetabular component.

## 6 EXPOSURE AND PREPARATION OF THE FEMORAL CANAL

A key to a successful *CPT* implantation is lateralization during femoral preparation. This assists in achieving axial alignment. Ensure medial bone removal at the greater trochanter to enable axial rasping and stem insertion. Preserve cancellous bone while rasping laterally and posteriorly.



## 7 LEG LENGTH AND OFFSET ADJUSTMENT

The ability to adjust leg length and offset at the time of the trial reduction is a distinctive feature of the trial reduction of this collarless design. The cobalt-chromium *CPT* System provides the possibility of choosing three different offsets for one stem body size.

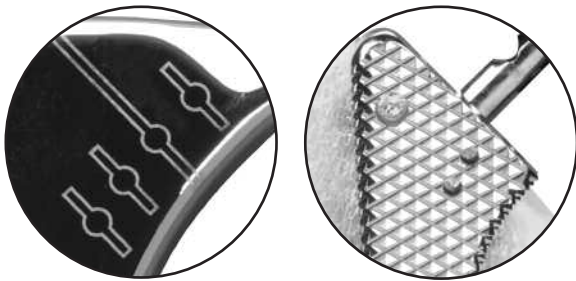

## 8 TRIAL REDUCTION

Use the final Rasp to perform a trial reduction and make necessary adjustments to length and offset. Note and mark the position of the nearest depth indicator mark on the Rasp in relation to the neck osteotomy and use this mark to determine stem position during insertion.

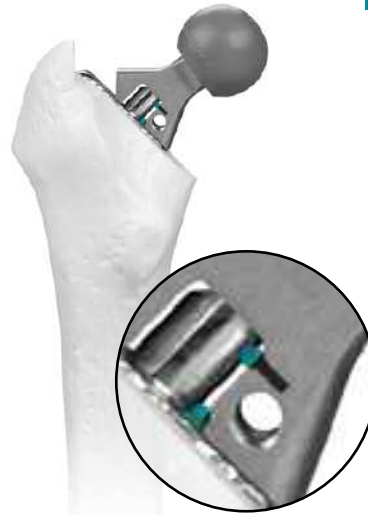

## 9 IMPLANTATION

Insert the medullary plug, prepare the canal, and introduce bone cement in a retrograde fashion while pressurizing. Assemble the stem and Stem Inserter, then attach the distal centralizer. Slowly insert the stem to the appropriate position while maintaining axial alignment. Perform a trial reduction to confirm leg length, offset, and range of motion. Then attach the final femoral head.



## 10 WOUND CLOSURE

Close the wound in layers and follow standard practices of postoperative care.





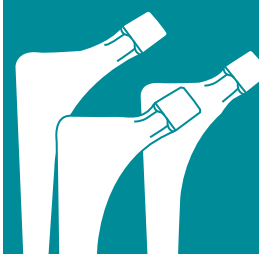

## PREOPERATIVE PLANNING

While preoperative planning is important, the versatility of the *CPT* Hip System makes intraoperative adjustments to leg length and offset a simple matter.

The overall objective of preoperative planning is to enable the surgeon to gather anatomic parameters which enhance intraoperative placement of the femoral implant.

The specific goals include:

1. Determination of leg length.
2. Establishment of appropriate abductor muscle tension by adjustment of femoral offset.
3. Determination of anticipated component sizing.
4. Determination of the osteotomy level above the superior border of the lesser trochanter.
5. Determination of lateralization into the trochanteric bed to achieve neutral alignment of the implant.

In femoral templating, it is important to appreciate that magnification of the size of the femur will vary depending on the distance from the x-ray source to the film and the distance from the patient to the film.

The *CPT* Hip System Templates use standard 20% magnification, which is close to the average magnification on most clinical x-ray films. Magnification for larger patients or obese patients may be greater than 20% because their osseous structures are farther away from the surface of the film. To determine the magnification of any x-ray film, a standardized marker may be placed at the level of the femur when exposing the film.

The center of rotation of the femoral head should be determined on the preoperative x-ray film. Throughout templating, the use of acetabular component templates and/or templating the opposite hip may help. Overlay the template on the A/P film so the midline of the implant is aligned with the anatomical axis in the femoral canal. Then move the template superiorly or inferiorly so the chosen head level mark is superimposed on the center of rotation of the femoral head (Fig. 1). The 12/14 taper and the three offset options provide multiple options to re-establish correct offset and leg length. Stem sizing is performed by choosing the stem size so the Rasp that fits the proximal femur will achieve an adequate cement mantle. Avoid oversizing and allow for an adequate bed of proximal cancellous bone approximately 3mm-4mm thick.



Fig. 1



The *CPT* Stems are available with standard, extended, and extra-extended offsets. This enables proper restoration of joint kinematics in hips that have different offsets. Stems with extended offsets provide an additional 5mm of offset without an increase in neck height. Stems with extra-extended offsets provide an additional 5mm of neck height as well as an additional offset, which is 10mm more offset than standard and 5mm more than extended-offset stems.

When the template is properly superimposed on the radiograph, note the neck osteotomy level and the height of the head center in relation to the tip of the greater trochanter. Head centers for each head/neck combination are shown in 3.5mm increments from -3.5mm to +10.5mm (depending on the head diameter). By using the neutral (+0mm) level to determine the level of the osteotomy cut, the surgeon has the option of using a neutral (+0mm) head, or one that is 3.5mm shorter (-3.5mm) or 3.5mm longer (+3.5mm) than the neutral femoral head without having to use a head with a metal skirt.

If more length is needed at the time of surgery, two additional femoral heads are available with neck lengths of 7mm (+7.0mm) and 10.5mm (+10.5mm) longer than the neutral (+0mm) neck length. These two heads with longer neck lengths have metal skirts. Use of femoral heads with metal skirts may reduce the range of motion of the joint after implantation.

Preoperative determination of leg length will assist in restoration of the appropriate leg length during surgery. Templating should take into account the preoperative measurement of leg length, the desired leg length, and the center of hip rotation, particularly in complex cases and revisions with an altered hip center.

Techniques that assist in leg length determination include measuring the distance from the head center to the lesser trochanter and/or to the height of the tip of the greater trochanter.

On the preoperative x-ray film, record the distance from the lesser trochanter and/or the vertical height of the tip of the greater trochanter to the center of rotation of the femoral head bilaterally by using the magnified ruler provided on the side of each template.

During surgery, a ruler can be used to measure these distances.

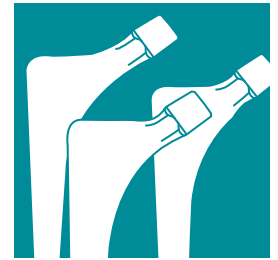

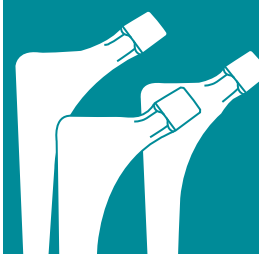

## SURGICAL TECHNIQUE

### Approach

In total hip arthroplasty, exposure can be achieved through a variety of methods. The primary *CPT* Implants can be inserted with equal ease using a posterolateral, anterolateral, straight lateral, or transtrochanteric approach.

For any of these approaches, position the patient in the appropriate position on the operating table and firmly maintain position throughout the surgery. The precise orientation of the acetabular component is facilitated by relating to this position as well as the bony landmarks of the pelvis. Prepare the skin in the usual way and drape the lower extremity.

Using the desired approach, expose the hip joint adequately to establish landmarks. For the posterolateral approach, center the incision over the greater trochanter and extend it proximally and distally as appropriate.

Divide the fascia lata longitudinally. Begin this division of the fascia lata at the distal end of the incision, particularly if there has been previous surgery in the area of the hip. Identification of the tissue planes is easiest at the distal end of the wound.

Develop the exposure of the posterior capsule. To facilitate this, place the leg in internal rotation. The key landmark for division of the short external rotators is the tendon of the piriformis muscle. This tendon runs parallel to the posterior border of the gluteus medius and can be readily palpated as it approaches the posterior superior portion of the greater trochanter. Retract the gluteus medius superiorly and identify the tendon of the piriformis. Divide the appropriate external rotators and incise the capsule.

### Determination of Leg Length

After exposing the joint, obtain baseline measurements before dislocating the hip so that a comparison of leg length and femoral shaft offset can be obtained after reconstruction. From this comparison, adjustments can be made to achieve the goals established during preoperative planning.

There are several methods to measure leg length. One method is to place one pin in the iliac wing and either place another pin parallel to the first pin in the greater trochanter, or mark the trochanter. With the leg in the neutral position, measure the distance between the two pins. It is important that the measurement be taken with the leg in the neutral position so the position can be easily and accurately reproduced after the new implant has been inserted. Leave the proximal pin in place, but remove the trochanteric pin and mark the pin site with electrocautery so it can be replaced for later measurement.

Zimmer also offers a device called the Joint Ruler (Fig. 2) that will measure leg length. To use the Joint Ruler, insert a 1/8-inch Steinman pin superior to the acetabular rim. Place the pin in the one o'clock position for an anterior approach or the 11 o'clock position for a posterior approach. Mark the femur using electrocautery. Secure the small end of the Joint Ruler by sliding it over the Steinman pin. Then align the ruler with the femoral marking and record the measurement.



Fig. 2

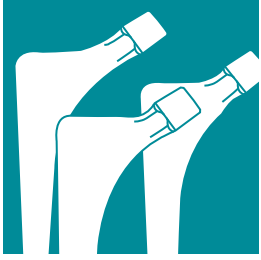

## Osteotomy of the Femoral Neck

Exposing the femoral neck may be assisted by retractors placed superiorly and inferiorly. The neck osteotomy level will vary depending on the size of the patient, the neck angle, and preoperative templating. The versatility of the collarless *CPT* Stem allows a wide range of insertion levels. Make a higher neck cut for large femurs or valgus femoral necks.

The resection level may be determined in a number of ways, including the following:

1. Place a finger above the lesser trochanter, approximating 2cm.
2. Use the Osteotomy Guide provided with the *CPT* System (Fig. 3). If you choose to use the Osteotomy Guide, please note that one guide is provided for all stem sizes. Superimpose the guide on the proximal femur. The longitudinal axis of the guide should be parallel to the longitudinal axis of the femur. Position the appropriate slot on the Osteotomy Guide over the center of rotation of the femoral head. The slot labeled “STD/EXT” is used for both the standard and extended offset stems, and the slot labeled “XEXT” is used for the extra-extended offset stems. Both refer to the neutral (+0mm) head center. If preferred, the Osteotomy Guide can also be positioned by using the scale on the medial edge of the guide to move the templated distance above the lesser trochanter, or by aligning the lateral slots with the tip of the greater trochanter.
3. Determine the midpoint between the lesser trochanter and the femoral head in relatively normal anatomical situations.

The level of the neck osteotomy may be marked with either a saw or methylene blue. Note that the angle of the osteotomy cut is approximately 45 degrees to the long axis of the femur (Fig. 4). Make the cut with a reciprocating saw in the neutral plane.



Fig. 3

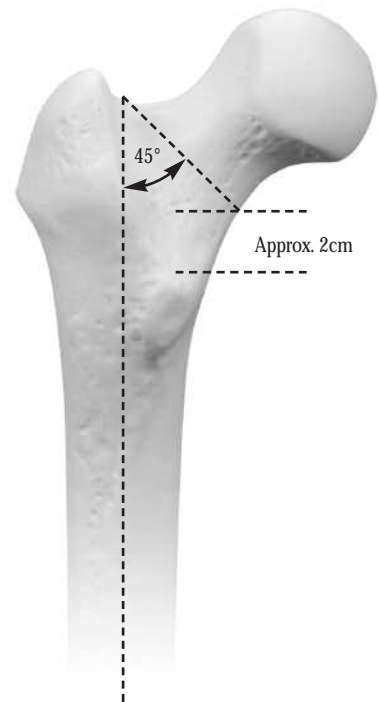

Fig. 4

### Preparation of the Acetabulum

After the femoral neck osteotomy is complete, prepare and implant the acetabular implants.

### Preparation of the Femoral Canal

Expose the proximal femur so there is unimpeded preparation of the canal and insertion of the stem. Use a femoral elevator and a trochanteric retractor that adequately retracts the gluteus medius and gluteus minimus muscles to assist with the exposure. Firmly but carefully rotate the femur while the leg is flexed at the knee to aide in femoral exposure.

It is critical that the gluteus medius tendon is retracted laterally to expose the greater trochanter. A small release incision in the insertion may assist. The medial part of the trochanter must be removed to ensure neutral placement of the Rasp and stem, thereby avoiding varus stem placement.

Open the proximal femur to the piriformis fossa by using the Box Osteotome or a combination of a gouge, rongeurs, or the Starter Awl. A burr may be helpful in sclerotic bone. The use of trochanteric power reamers should be confined to removing only lateral trochanteric bone. Power reamers should not be used to prepare the femoral canal because of the danger of excessive cancellous bone removal.

Locate and open the femoral canal using the blunt Starter Awl or a sharp T-handle reamer for sclerotic bone. Use the Medium Awl and Large Awl in progression to widen the femoral canal while working laterally and posteriorly into the greater trochanter. Ensure that the awls are aligned axially within the femoral canal (Fig. 5), using femoral landmarks and the knee as guides. Caution should be exercised using the larger T-handle awls in small diameter canals.

To help ensure that the stem is not placed in varus, it is important to aggressively remove medial bone in the area of the greater trochanter. This will allow the canal to be opened so that the Rasps and femoral component may be inserted along the femoral axis.

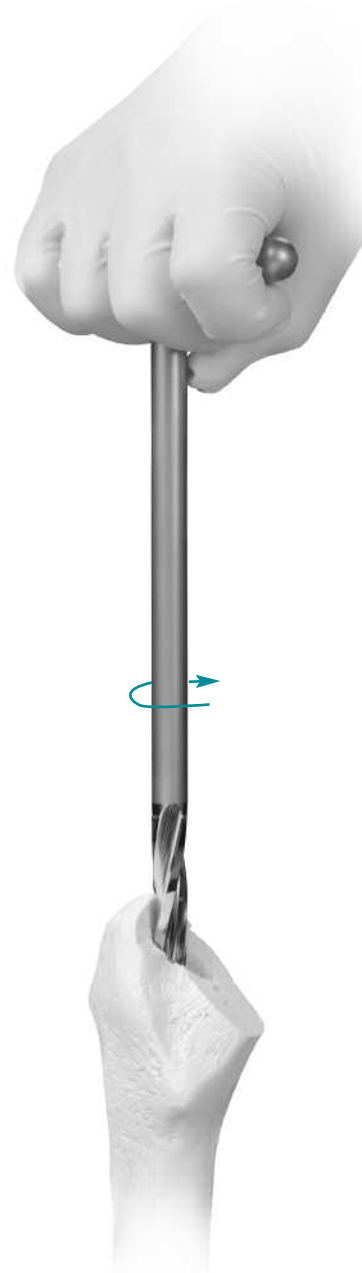
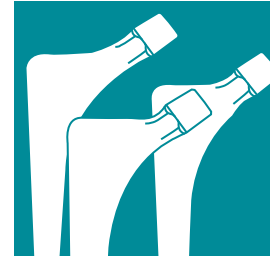
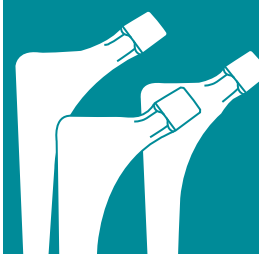

Fig. 5



Begin femoral rasping with a Rasp that is one to two sizes smaller than the templated size (Fig. 6). Then use sequentially larger Rasps until the templated size is reached, or until adequate resistance is obtained. Avoid over-rasping; leave an adequate bed of 3mm to 4mm of cancellous bone proximally (Fig. 7). The entire procedure may be achieved through hand rasping only, using light taps with the mallet to dislodge the Rasp. Alternatively, the mallet may be used gently to insert the Rasps. The Rasps should advance with each moderate tap of the mallet. Do not tap the Rasp again once it has stopped advancing.

Rasp laterally and posteriorly in the femoral neck to aid in optimal placement of the Rasp and final component. Anteversion may be determined by choosing a standard degree of anteversion of approximately 10 degrees, or by the patient's natural anteversion, or at the surgeon's discretion based on the particular patient.

Soft cancellous bone may be removed with a curette from regions the Rasp did not reach, especially laterally and medially at the level of the lesser trochanter.



Fig. 6



Fig. 7

## Trial Reduction

The 12/14 system provides improved kinematic function by offering up to three offsets for each stem body size to help re-establish the femoral head center. Due to the strength of cobalt-chromium, offset designs which allow the surgeon to change from standard offset to extended offset to extra-extended offset without rasing have been realized. The collarless design also greatly simplifies leg length adjustment. The 12/14 taper enables a wide selection of femoral head/stem combinations and the optimized neck geometry enhances range of motion.

With the final Rasp in the canal, attach the appropriate Cone Provisional and Femoral Head Provisional to the Rasp trunnion (Fig. 8). Please note that Rasps are used for most of the primary stem trial reductions, but Stem Provisionals are provided for the small and extra-small stems. Small and extra-small Stem Provisionals model the stem and the cement mantle, so there is an increase in cross section at the osteotomy line (Fig. 9).

The Cone Provisionals replicate the neck geometry of the femoral component for exact trial reductions. The CPT System uses one Rasp for each stem size; however, a Cone Provisional is provided for each offset of the stem. The Cone Provisionals are labeled “STD”, “EXT”, and “XEXT” for standard, extended, and extra-extended offsets, respectively. An etch mark on the Cone Provisional (Fig. 8) corresponds to the etch mark 5mm above the osteotomy line on the stem.

Perform a trial reduction and, if necessary, adjust the provisional components to optimize joint stability, leg length, and range of motion. Aim for a neutral head center (+0mm) to avoid the need for a skirted head (+7.0mm and +10.5mm). Observe the relationship of the center of the femoral head to the top of the greater trochanter to confirm the preoperative plan. Check the sciatic nerve tension and range of motion, and confirm positions of potential instability. Also, confirm that the preoperative goal for leg length has been achieved by using the preferred method of measurement.

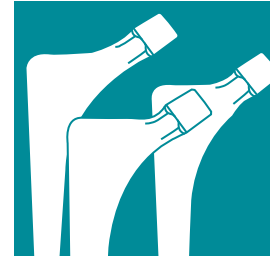

Fig. 8



Fig. 9



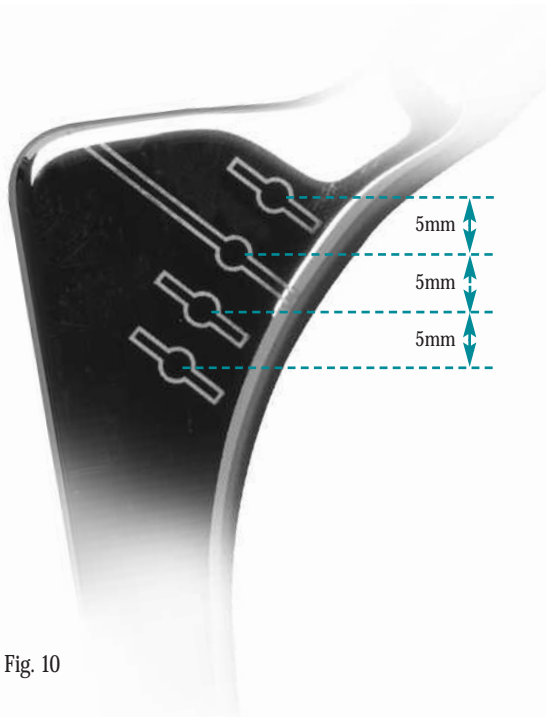
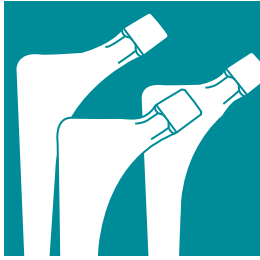

Fig. 10



Fig. 11



Fig. 12

The *CPT* Rasps have depth indicator holes that correspond to the depth indicator markings on the final implant (Fig. 10). **Note: In some instances there may be more depth indicators on the Rasp than on the final implant. The number of depth indicators decreases with increased offset.** These indicators are 5mm apart. If good proximal bone is present and it is desired to seat the stem slightly proud, insert a Trial Locating Pin into the appropriate hole to maintain the proud position during the trial reduction (Fig. 11). Where there is loss of or insufficient proximal femoral bone stock, the stem should not be seated proud. Note the insertion depth.

#### Depth Indicators Below Osteotomy Line

Stem Size	STD	EXT	XEXT
Small	0	na	na
X-Small	0	na	na
0	2	0	na
1	2	1	na
2	2	2	1
3	2	2	2
4	2	2	2
5	2	2	2

\* Small and X-Small have no depth indicator above osteotomy line. All other stems have one indicator above the osteotomy line.

One way to aid in avoiding varus stem placement is to mark the calcar bone at the point corresponding to the nearest depth hole on the Rasp (Fig. 12). This will be used as a reference mark by aligning with the corresponding mark on the stem during insertion. Then remove the Rasp and provisional components.

## Component Implantation

Use the Medullary Canal Sizers to determine the appropriate size of the Allen Medullary Bone Plug. One technique is to use the plug with the core size that corresponds to the last sizer that passed through the isthmus.

Use the disposable Allen Medullary Bone Plug Inserter to insert the bone plug to the mark on the inserter which corresponds to approximately 2.5cm below the tip of the stem. If preferred, use the Distal Plug Inserter supplied with the CPT Hip System.

This instrument has marks on one side which indicate the depth of insertion of the plug for different stems (Fig. 13). The other side of the inserter has marks every centimeter (Fig. 13 inset). Position the inserter laterally in the femur. Align it in the same orientation of the midline of the stem. Introduce the plug with gentle hammering until the mark for the chosen stem is level with the oblique neck cut. If in doubt, check to be sure that the bone plug is inserted to a depth that will accommodate the selected stem length by inserting the Rasp.

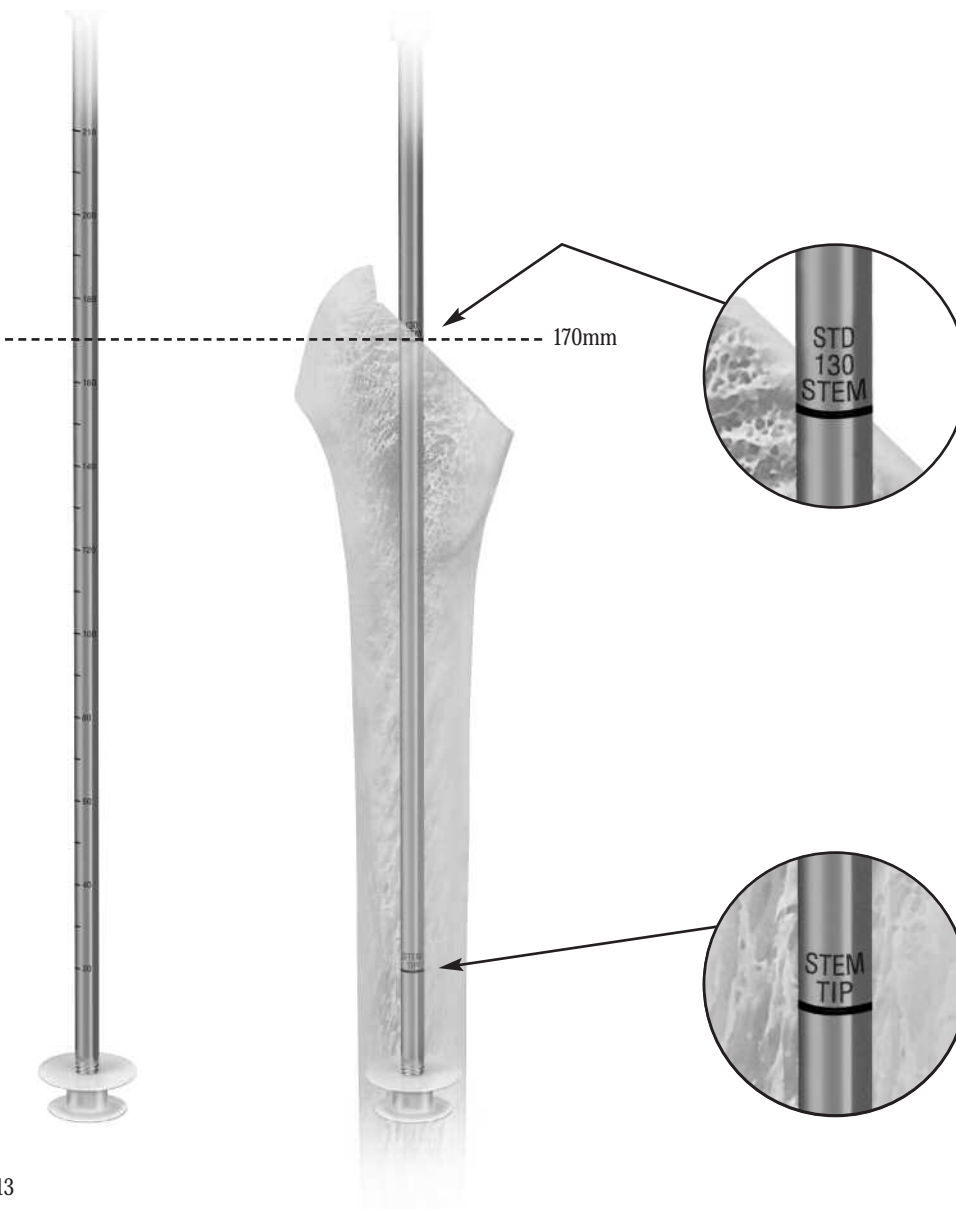
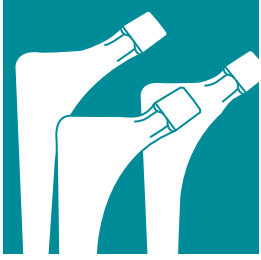

Fig. 13



Once the femoral canal is prepared, use pulsatile lavage to remove any loose bone and control bleeding. One technique is the use of a femoral brush followed by pulsatile lavage, insertion of a thin plastic suction tube, and femoral packing. The pack can be presoaked in a variety of substances that are used to minimize bleeding. The PMMA bone cement is introduced in a relatively low viscosity state. Using a cement gun, inject cement into the canal in a retrograde fashion. When the canal is filled, cut or break off the cement nozzle and place the Femoral Pressurizer Seal on the cement gun nozzle. Inject additional cement, maintaining pressure until the cement reaches a doughy state (Fig. 14).



Fig. 14

The Femoral Pressurizer Plate can be used to enhance pressure applied to the seal (Fig. 15). Cement polymerization time varies according to a number of factors, including temperature and humidity.



Fig. 15

Attach the distal centralizer to the femoral stem (Fig. 16) by pushing it on with a twisting motion. Two distal centralizers (Fig. 17) are available. The Standard Distal Centralizer has wings and is recommended for use with sizes 1 through 5, as well as long stems.

The Revision Distal Centralizer has no wings and is used with sizes extra-small, small and 0, as well as during impaction grafting procedures. The recommended centralizer is packaged with the stem.



Fig. 16



Fig. 17

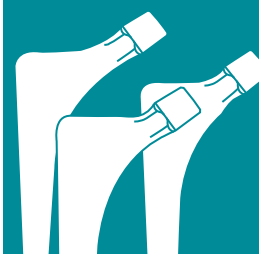

Attach the femoral component to the Stem Inserter by placing the release lever in the engage position, marked “E” (Fig. 18), and turning the barrel to loosely thread the inserter onto the stem. Do not overtighten. A small protuberance on the inserter adjacent to the screw attachment engages the dimple on the stem shoulder to control component anteversion during insertion. Note that the extra-small stem does not have a threaded hole or a dimple for insertion and should be inserted by hand.

Place the thumb or finger over the medial anterior femoral neck (Fig. 19) while inserting the stem to maintain cement pressure. This will help to ensure that the stem remains aligned axially, without moving into varus or shifting anteriorly. There should be 4mm of cement on the medial side of the stem. Slowly advance the stem into the cement mantle.

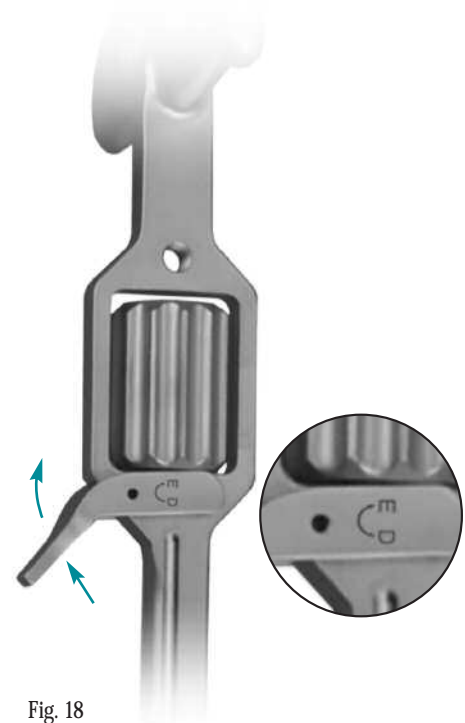
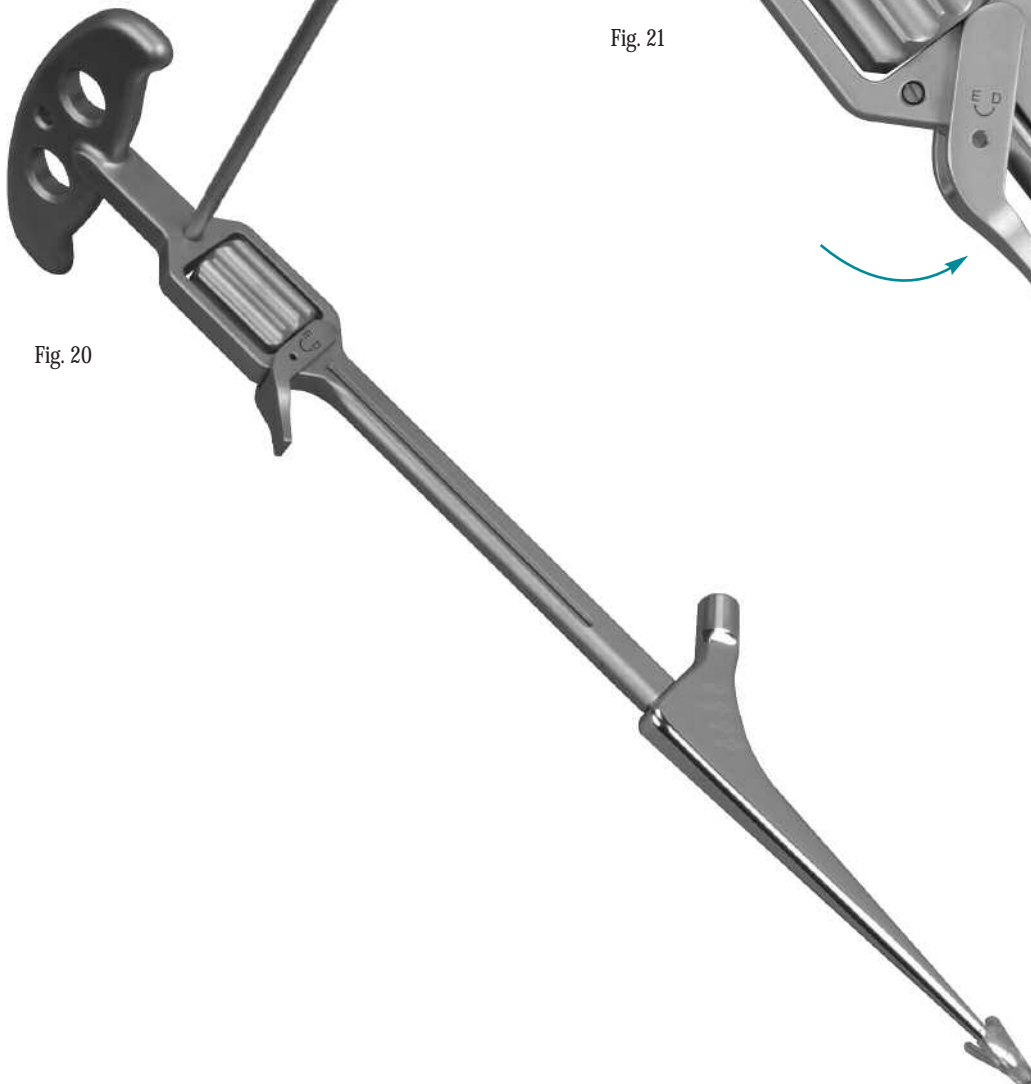

Fig. 18

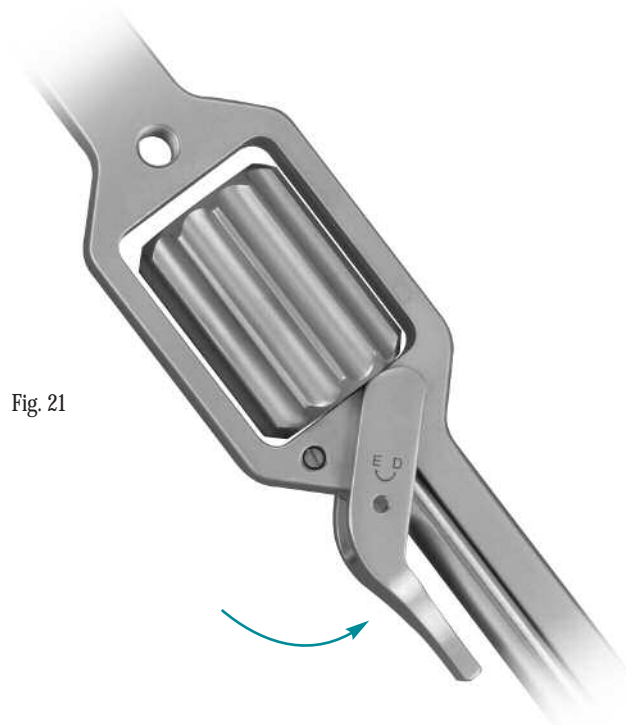

Fig. 19

The Stem Inserter has a mark along the stem center line to aid in insertion. The Stem Inserter also has a threaded hole between the handle and barrel to assemble the Anteversion Rod (Fig. 20). The Anteversion Rod may be assembled on either side and represents a reference for zero degrees of anteversion. Insert the stem tending towards valgus. Pause approximately a centimeter proud to make sure the cement is viscous enough to support the stem. Insert the stem to the final position as determined by the depth/alignment marks on the stem and the mark on the femoral neck.



An alternative technique is to apply the Cement Restrictor and Cement Restrictor Plate to the femoral neck and insert the stem through this. Stabilize the stem with one hand. Continue to support the inserter while flipping the release lever to the disengage position marked "D" (Fig. 21), unscrewing the barrel and removing the inserter.



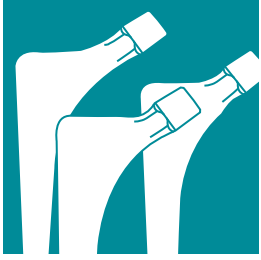

The aim is to have the stem reach its final position as the cement becomes quite viscous, thereby maintaining pressure on the cement. As with all stems, on occasion it becomes clear the stem needs gentle hammering because the cement is too viscous. A useful technique is to have the assistant maintain the stem in axial alignment and anteversion while the surgeon gently taps the stem down to the chosen depth indicator in a controlled manner (Fig. 22).

It is recommended to gently push a small amount of lateral cement over the lateral shoulder of the stem with a curette or finger so that stem subsidence within the cement may be evaluated on radiographs (Fig. 23). This helps prevent the remote possibility of the stem backing out inadvertently should a postoperative dislocation require reduction.



Fig. 22



Fig. 23



Clear residual cement from the femoral neck. Apply the Cement Restrictor and Cement Restrictor Plate if needed. Maintain pressurization and stem position until the cement hardens.

Once the cement has hardened, the Femoral Head Provisional may be used during a trial reduction to assess the leg length, range of motion, stability, abductor tension, and to confirm final femoral head size.

One advantage of the CPT System is that the stem can be removed from the cement mantle if necessary, even after the cement has cured.

**Note: The Stem Inserter is not intended for use to remove the stem. A Stem Extractor Adapter is included in the General Instrument Set for this purpose.**

Check to ensure that the 12/14 neck taper is clean and dry. Place the femoral head on the taper with a twisting motion until it locks on the taper. Place a pack or swab over the femoral head to protect it and then seat the femoral head with one sharp strike using the Femoral Head Impactor and mallet. Test the security of the head fixation by trying to remove the head by hand.

Protect the femoral head with gauze and hold it away from the acetabulum to avoid inadvertent impingement. Then clean the acetabulum and reduce the joint. Remove the gauze from the femoral head as the head is reduced.

### Wound Closure

After obtaining hemostasis, insert a Hemovac® Wound Drainage Device, if desired. Then close the wound in layers.

## REFERENCES

1. Weidenhielm LRA, Mikhail WEM, Nelissen RGHH, Bauer TW. Cemented collarless (Exeter-C.P.T.) femoral components versus cementless collarless (P.C.A.) 2-14 year follow-up evaluation. *J Arthroplasty*. 1995;10(5):592-597.
2. Malchau H, Herberts P. Prognosis of total hip replacement. Scientific exhibition at: 65th Annual Meeting of The American Academy of Orthopaedic Surgeons; March 19-23, 1998; New Orleans, Louisiana.
3. Fowler JL, Gie GA, Lee AJC, Ling RSM. Experience with the Exeter total hip replacement since 1970. *Orthop Clin N Am*. 1988;19:477.
4. Yates P, Gobel D, Bannister G. Collarless polished tapered stem. *J Arthroplasty*. 2002;17(2):189-195.
5. Danish Hip Arthroplasty Registry, Annual Report, Aarhus University Hospital, Department of Orthopaedic Surgery, October 2002.
6. Lee AJC, Perkins RD, Ling RSM. Time-dependent properties of polymethylmethacrylate bone cement.
7. McKellop H, Narayan S, Ebramzadeh E, Sarmiento A. Viscoelastic creep properties of PMMA surgical cement. Presented at: The Third World Biomaterials Congress; April 21-25, 1988; Kyoto, Japan.
8. Data on file at Zimmer.



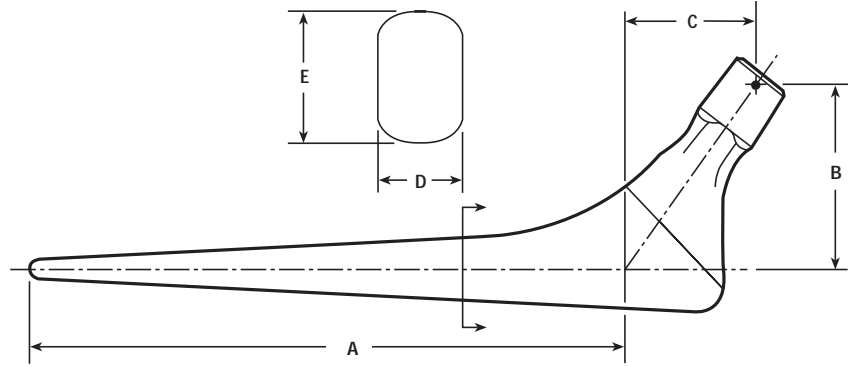

Prod. No. Standard Offset	Stem Size (mm)	A Stem Length (mm)	B Offset (mm) When Head/Neck Component Selected is:					C Neck Height (mm) When Head/Neck Component Selected is:					D A/P Width	E M/L Width
			-3.5	0	+3.5	+7	+10.5	-3.5	0	+3.5	+7	+10.5		
8114-00	0-STD	105	29	32	35	37	40	24	26	28	30	32	7.5	9.0
8114-01	1-STD	130	31	34	37	39	42	24	26	28	30	32	9.0	10.5
8114-02	2-STD	130	33	36	38	41	44	24	26	28	30	32	9.0	13.0
8114-03	3-STD	130	35	37	40	43	46	24	26	28	30	32	9.0	15.5
8114-04	4-STD	130	35	38	41	44	46	24	26	28	30	32	10.0	17.5
8114-05	5-STD	130	37	40	43	45	48	24	26	28	30	32	10.0	20.0
<b>Extended Offset</b>														
8114-00-10	0-EXT	105	34	37	40	42	45	24	26	28	30	32	7.5	9.0
8114-01-10	1-EXT	130	36	39	42	44	47	24	26	28	30	32	9.0	10.5
8114-02-10	2-EXT	130	38	41	43	46	49	24	26	28	30	32	9.0	13.0
8114-03-10	3-EXT	130	40	42	45	48	51	24	26	28	30	32	9.0	15.5
8114-04-10	4-EXT	130	40	43	46	48	51	24	26	28	30	32	10.0	17.5
8114-05-10	5-EXT	130	42	45	47	50	53	24	26	28	30	32	10.0	20.0
<b>Extra Extended Offset</b>														
8114-02-30	2-XEXT	130	43	46	48	51	54	29	31	33	35	37	9.0	13.0
8114-03-30	3-XEXT	130	45	47	50	53	56	29	31	33	35	37	9.0	15.5
8114-04-30	4-XEXT	130	45	48	51	53	56	29	31	33	35	37	10.0	17.5
8114-05-30	5-XEXT	130	47	50	52	55	58	29	31	33	35	37	10.0	20.0
<b>Small</b>														
8114-40	X-Small	85	25	28	31	34	37	21	23	25	27	29	7.0	8.0
8114-50	Small	95	27	30	33	36	39	22	24	26	28	30	7.5	9.0
<b>Revision - Long</b>														
8114-02-18	2, 180mm	180	33	36	38	41	44	24	26	28	30	32	9.5	13.0
8114-12-18	2, 180mm VN	180	33	36	38	41	44	39	41	43	45	47	9.5	13.0
8114-03-18	3, 180mm	180	40	42	45	48	51	24	26	28	30	32	9.5	16.0
8114-13-18	3, 180mm VN	180	40	42	45	48	51	39	41	43	45	47	9.5	16.0
8114-04-20	4, 200mm	200	40	43	46	49	51	24	26	28	30	32	11.0	16.0
8114-04-23	4, 230mm	230	40	43	46	49	51	24	26	28	30	32	11.0	16.0
8114-04-26	4, 260mm	260	40	43	46	49	51	24	26	28	30	32	11.0	16.0

**CPT INSTRUMENT SETS**

Prod. No.	Description
8334-00-01	CPT Extra Small-Size 3 Instrument Set
8334-00-02	CPT Primary Instrument Set
8334-00-03	CPT Revision Supplementary Instrument Set
8334-00-04	CPT Impaction Grafting Instrument Set
8334-00-05	CPT Extra Small/Small Supplementary Instrument Set
<b>8334-00-02 CPT Primary Instrument Set</b>	
8334-30	General Instrument Case Assembly
8334-14	Osetotomy Guide
31-8334-05	Stem Extractor Adapter
6601-54	Box Osteotome, Sm
6601-56	Box Osteotome, Lrg
8334-65	Starter Awl, 8mm
8334-65-01	Medium Awl, 11mm dia
8334-65-02	Large Awl, 14mm dia
8334-35	Primary Instrument Case Assembly
8334-10	Rasp Handle
8334-11	Trial Locating Pin
8334-13	Stem Inserter
8334-60	Size 0 Rasp
8334-60-01	Size 1 Rasp
8334-60-02	Size 2 Rasp
8334-60-03	Size 3 Rasp
8334-60-04	Size 4 Rasp
8334-60-05	Size 5 Rasp
31-8334-13	Cement Restrictor Plate
8334-80-10	Femoral Pressurizer Plate
8334-15	Size 0 Std Cone Prov
8334-15-01	Size 1 Std Cone Prov
8334-15-02	Size 2 Std Cone Prov
8334-15-03	Size 3 Std Cone Prov
8334-15-04	Size 4 Std Cone Prov
8334-15-05	Size 5 Std Cone Prov
8334-20	Size 0 Ext Cone Prov
8334-20-01	Size 1 Ext Cone Prov
8334-20-02	Size 2 Ext Cone Prov
8334-20-03	Size 3 Ext Cone Prov
8334-20-04	Size 4 Ext Cone Prov
8334-20-05	Size 5 Ext Cone Prov
8334-25-02	Size 2 X-Ext Cone Prov
8334-25-03	Size 3 X-Ext Cone Prov
8334-25-04	Size 4 X-Ext Cone Prov
8334-25-05	Size 5 X-Ext Cone Prov
7895-28-01	Fem Head Prov, 28mm -3.5
7895-28-02	Fem Head Prov, 28mm +0
7895-28-03	Fem Head Prov, 28mm +3.5
7895-28-04	Fem Head Prov, 28mm +7
7895-28-05	Fem Head Prov, 28mm +10.5

**CPT INSTRUMENT SETS (CONT.)**

Prod. No.	Description
<b>8334-00-03</b>	<b>CPT Revision Supplementary Instrument Set</b>
8334-40	Revision Instrument Case Assembly
8334-60-22	Size 2 Rasp, 180mm
8334-60-23	Size 3 Rasp, 180mm
8334-60-24	Size 4 Rasp, 200mm
8334-70-25	Size 4 Stem Prov, 230mm
8334-70-26	Size 4 Stem Prov, 260mm
8334-26-02	Size 2 Valgus Nk Cone Prov
8334-26-03	Size 3 Valgus Nk Cone Prov
This is to be used with the Primary Instrument Set.	
<b>8334-00-05</b>	<b>CPT Extra Small/Small Supplementary Instrument Set</b>
8334-45	Extra Small/Small Instrument Case Assembly
8334-60-40	Extra Small Rasp
8334-60-50	Small Rasp
8334-15-40	Extra Small Stem Prov
8334-15-50	Small Stem Prov
7895-22-20	Fem Head Prov, 22mm -2
7895-22-02	Fem Head Prov, 22mm +0
7895-22-30	Fem Head Prov, 22mm +3
This is to be used with the Primary Instrument Set.	
<b>8334-00-01</b>	<b>CPT Extra Small-Size 3 Instrument Set</b>
8334-30	General Instrument Case Assembly
8334-14	Osetotomy Guide
31-8334-05	Stem Extractor Adapter
6601-54	Box Osteotome, Small
6601-56	Box Osteotome, Large
8334-65	Starter Awl, 8mm
8334-65-01	Medium Awl, 11mm dia
8334-65-02	Large Awl, 14mm dia
8334-50	Extra Small-Size 3 Instrument Case Assembly
8334-10	Rasp Handle
8334-11	Trial Locating Pin
8334-13	Stem Inserter
8334-60	Size 0 Rasp
8334-60-01	Size 1 Rasp
8334-60-02	Size 2 Rasp
8334-60-03	Size 3 Rasp
8334-60-40	Extra Small Rasp
8334-60-50	Small Rasp
31-8334-13	Cement Restrictor Plate
8334-80-10	Femoral Pressurizer Plate
8334-15	Size 0 Std Cone Prov
8334-15-01	Size 1 Std Cone Prov
8334-15-02	Size 2 Std Cone Prov
8334-15-03	Size 3 Std Cone Prov
8334-20	Size 0 Ext Cone Prov
8334-20-01	Size 1 Ext Cone Prov
8334-20-02	Size 2 Ext Cone Prov
8334-20-03	Size 3 Ext Cone Prov
8334-25-02	Size 2 X-Ext Cone Prov
8334-25-03	Size 3 X-Ext Cone Prov
8334-15-40	Extra Small Stem Prov
8334-15-50	Small Stem Prov

**CPT INSTRUMENT SETS (CONT.)**

Prod. No.	Description
8334-50	Extra Small-Size 3 Instrument Case Assembly - Continued
7895-28-01	Fem Head Prov, 28mm -3.5
7895-28-02	Fem Head Prov, 28mm +0
7895-28-03	Fem Head Prov, 28mm +3.5
7895-28-04	Fem Head Prov, 28mm +7
7895-28-05	Fem Head Prov, 28mm +10.5
7895-22-20	Fem Head Prov, 22mm -2
7895-22-02	Fem Head Prov, 22mm +0
7895-22-30	Fem Head Prov, 22mm +3

**STERILE PACKED ITEMS**

Prod. No.	Description
32-8334-10-01	Femoral Pressurizer Seal, Sm
32-8334-10-02	Femoral Pressurizer Seal, Lrg

**CO-CR FEMORAL HEAD OPTIONS**

Prod. No.	Description
8018-22-20	Fem Head -2 x 22mm Dia
8018-22-02	Fem Head 0 x 22mm Dia
8018-22-30	Fem Head +3 x 22mm Dia
8018-26-01	Fem Head -3.5 x 26mm Dia
8018-26-02	Fem Head 0 x 26mm Dia
8018-26-03	Fem Head +3.5 x 26mm Dia
8018-26-04	Fem Head +7 x 26mm Dia
8018-26-05	Fem Head +10.5 x 26mm Dia
8018-28-01	Fem Head -3.5 x 28mm Dia
8018-28-02	Fem Head 0 x 28mm Dia
8018-28-03	Fem Head +3.5 x 28mm Dia
8018-28-04	Fem Head +7 x 28mm Dia
8018-28-05	Fem Head +10.5 x 28mm Dia
8018-32-01	Fem Head -3.5 x 32mm Dia
8018-32-02	Fem Head 0 x 32mm Dia
8018-32-03	Fem Head +3.5 x 32mm Dia
8018-32-04	Fem Head +7 x 32mm Dia
8018-32-05	Fem Head +10.5 x 32mm Dia
8018-36-01	Fem Head -3.5 x 36mm Dia
8018-36-02	Fem Head 0 x 36mm Dia
8018-36-03	Fem Head +3.5 x 36mm Dia
8018-36-04	Fem Head +7 x 36mm Dia
8018-36-05	Fem Head +10.5 x 36mm Dia
8018-40-01	Fem Head -3.5 x 40mm Dia
8018-40-02	Fem Head 0 x 40mm Dia
8018-40-03	Fem Head +3.5 x 40mm Dia
8018-40-04	Fem Head +7 x 40mm Dia
8018-40-05	Fem Head +10.5 x 40mm Dia



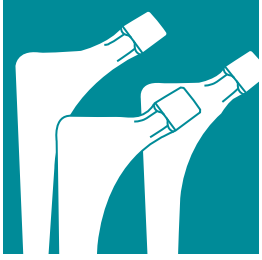





**zimmer**  
Confidence in your hands®



Please refer to package insert for complete product information, including contraindications, warnings, precautions, and adverse effects.

Contact your Zimmer Representative or visit us at [www.zimmer.com](http://www.zimmer.com).



+H124978114002001/\$030312R1 B08I