

stryker®

Orthopaedics

**MDM<sup>®</sup>X3<sup>®</sup>**

**Modular** Dual Mobility Acetabular System

# Surgical Technique

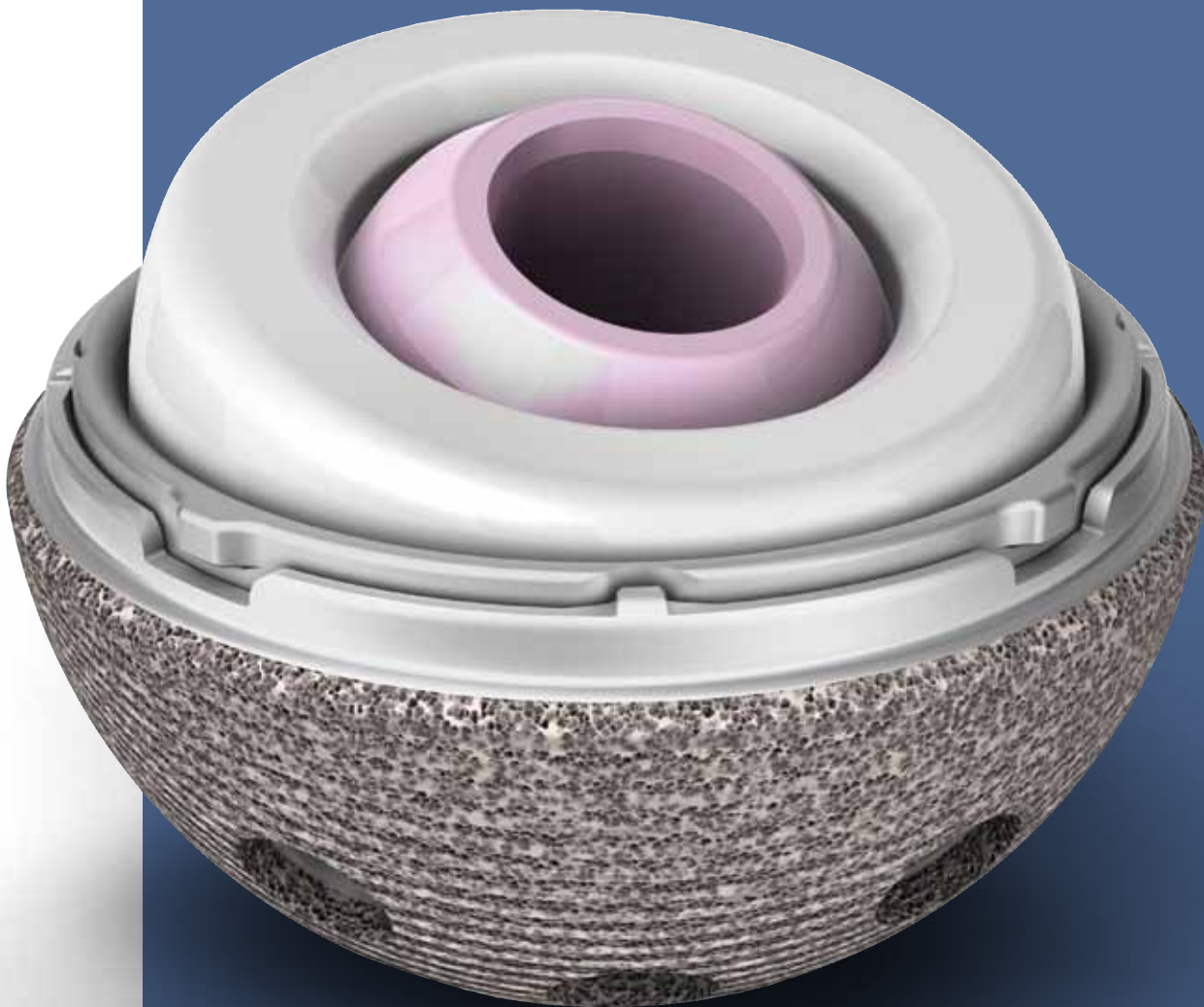

## INDICATIONS

---

The indications for use of total hip replacement prostheses include:

- Non-inflammatory degenerative joint disease including osteoarthritis and avascular necrosis.
- Rheumatoid arthritis.
- Correction of functional deformity.
- Revision procedures where other treatments or devices have failed.
- Treatment of non-union, femoral neck and trochanteric fractures of the proximal femur with head involvement that are unmanageable using other techniques.
- Dislocation risks.

*\*The Modular Dual Mobility (MDM) Liner is intended for cementless use only.*

## CONTRAINDICATIONS

---

- Overt infection.
- Distant foci of infections (which may cause hematogenous spread to the implant site).
- Rapid disease progression as manifested by joint destruction or bone resorption apparent on roentgenogram.
- Skeletally immature patients.
- Cases where there is a loss of abductor musculature, poor bone stock or poor skin coverage around the hip joint which would make the procedure unjustifiable.

## CONDITIONS PRESENTING INCREASED RISK OF FAILURE:

---

- Uncooperative patient or patient with neurologic disorders, incapable of following instructions;
- Osteoporosis;
- Metabolic disorders which may impair bone formation; or,
- Osteomalacia.

## WARNINGS AND PRECAUTIONS

---

See package insert for warnings, precautions, adverse effects and other essential product information. The MDM Liner is intended for use with Trident or Tritanium acetabular cups only. Additionally, the MDM Liner is not intended for use as a metal-on-metal or ceramic-on-metal articulation. No testing has been conducted to determine that these bearing couples produce favorable mechanical outcomes. Only Stryker 22.2mm or 28mm femoral heads should be inserted into the ADM/MDM polyethylene inserts. Further, do not substitute another manufacturer's device for any component of the ADM/MDM Acetabular System. Any such use will negate the responsibility of Howmedica Osteonics Corp. for the performance of the resulting mixed component implant.

Before using MDM instrumentation, verify:

- Instruments have been properly disassembled prior to cleaning and sterilization;
- Instruments have been properly assembled post-sterilization;
- Instruments have maintained design integrity; and,
- Proper size configurations are available.

## TABLE OF CONTENTS

---

Pre-operative Planning and X-ray Evaluation . . . . .	2
Acetabular Preparation . . . . .	3
Spherical Reaming . . . . .	4-5
Final Reaming . . . . .	6
Trial Evaluation . . . . .	7
Shell Implantation . . . . .	8-9
Optional Screw Utilization . . . . .	10-11
Trial Insert Reduction . . . . .	12
Liner Implantation . . . . .	12-13
Trial Insert/Head Reduction . . . . .	14-16
Insert/Head Implantation . . . . .	17
Reduction and Closure . . . . .	18
Removal Options . . . . .	19
Catalog Information . . . . .	20-23

# MDMX3

## INTRODUCTION

**Modular** Dual Mobility Acetabular System

**TABLE 1:** MDM Liner and Insert Compatibility with Trident and Tritanium Shells

	SHELL SIZE (mm), LINER ALPHA CODE							
Trident PSL Shell	44	46, 48	50, 52	54, 56	58, 60	62, 64	66, 68	70, 72
Trident Hemispherical Shell	46	48, 50	52, 54	56, 58	60, 62	64, 66	68, 70	72, 74
Tritanium Hemispherical Shell	48	50, 52	54, 56	58, 60	62, 64	66, 68	70, 72	74-80
Liner Alpha Code	C	D	E	F	G	H	I	J
MDM CoCr Liner	36C	38D	42E	46F	48G	52H	54I	58J
Poly Insert OD (mm)	36	38	42	46	48	52	54	58
Poly Insert ID (mm)	22.2	22.2	28	28	28	28	28	28
Nominal Poly Thickness (mm)	6.7	7.7	6.8	8.8	9.8	11.8	12.8	14.8

### DESIGN RATIONALE

The MDM System incorporates the following dual points of articulation:

- 22.2mm or 28mm femoral head; and,
- Large polyethylene insert that mimics a femoral head.

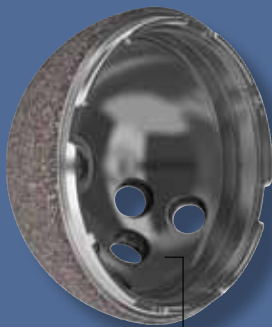

**Acetabular Shell**



**MDM CoCr Liner**

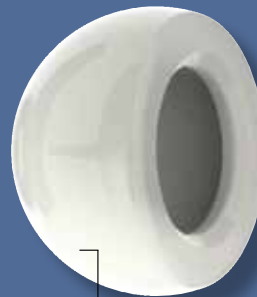

**Poly Insert**



**Femoral Head**

# STEP 1

## PRE-OPERATIVE PLANNING AND X-RAY EVALUATION



- Pre-operative planning and X-ray evaluation aids in the selection of the most favorable implant design and optimal size for the patient's hip pathology. Pre-operatively selecting potential implant designs and sizes can facilitate operating room preparation and assure availability of appropriate sizes.
- X-ray evaluation may also help detect anatomic anomalies that could prevent the intra-operative achievement of the established pre-operative goals.

# STEP 2

## ACETABULAR PREPARATION



### NOTE

Careful identification and removal of osteophytes can help reduce the possibility of bone-to-bone or component-to-bone impingement.

Additionally, this can aid in the identification of bony landmarks used for cup positioning.

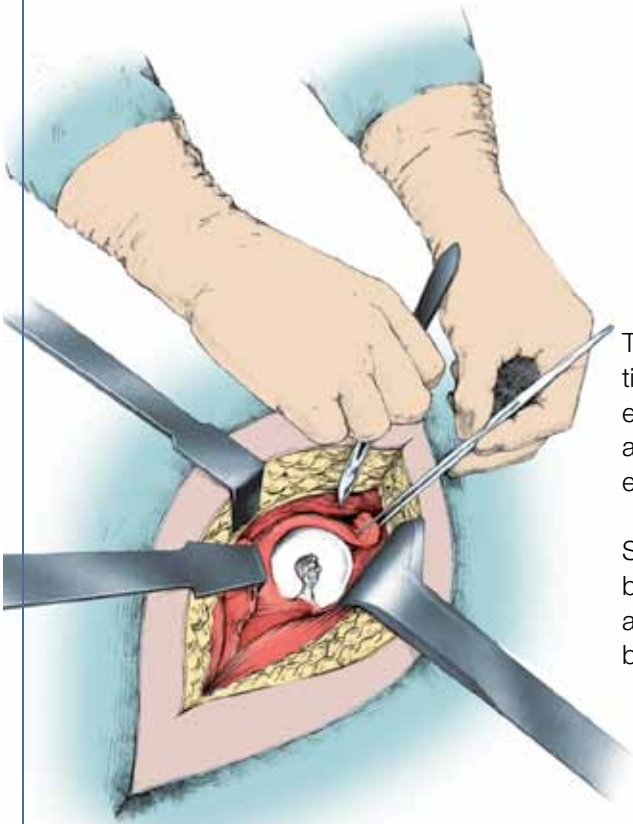

The acetabulum is prepared by the release and removal of soft tissue using the surgeon's preferred technique to gain adequate exposure for reaming. Excision of the labrum and osteophytes allows for proper visualization of the bony anatomy and improves ease of reaming.

Stryker Orthopaedics' Femoral and Wing Retractors can be utilized to gain acetabular exposure (Figure 1). With the acetabulum exposed, bony defects can be identified. If necessary, bone grafting options may be considered.

Figure 1

# STEP 3A

## SPHERICAL REAMING



### CAUTION

Only the CuttingEdge Spherical Reamers should be used to prepare the acetabulum for the Trident or Tritanium acetabular shell components.



Figure 2

To obtain optimal component positioning in the reaming process, a 45°/20° Abduction/Anteversion Alignment Guide can be attached to the CuttingEdge Reamer Handle (Figure 2).

The alignment guide, when perpendicular to the long axis of the patient, will orient the reamer handle at 45° of abduction, thereby placing the axis of the spherical reamer at 45° of inclination (Figure 3). The reamer handle may be positioned at 20° of anteversion by aligning the left/right anteversion rod on the alignment guide so that it is parallel to the long axis of the patient.



Figure 3

It is recommended that the initial reaming begin with a CuttingEdge Spherical Reamer that is 4mm smaller than the templated or gauged size. The reamer is attached to the reamer handle by pushing down on the reamer and applying a quarter-turn to lock in place. Reaming progresses in 1mm increments until final sizing is achieved. Surgical judgment is used to assess bone stock, amount of interference, adequacy of medialization and proper amount of reaming as desired.



### CAUTION

All external alignment guides depend on knowing that the patient is in a lateral decubitus position and that there is no pelvic tilt.



### NOTE

Changes in pelvic tilt and pelvic flexion caused by patient positioning on the table, as well as disease in contralateral hip, spine and pelvis may impact a surgeon's ability to achieve component placement of 45°/20° abduction/anteversion.



### TIPS

**William A. Leone, Jr., M.D.**  
“To achieve the recommended 45° abduction and 20° anteversion, an optional Pelvic Alignment Level (PAL) may be used. For recommended technique, refer to the PAL Surgical Protocol, LSP61.”

**John Andronaco, M.D.**  
“Be sure to check for and remove internal osteophytes prior to reaming for the implant to prevent lateralizing the shell.”

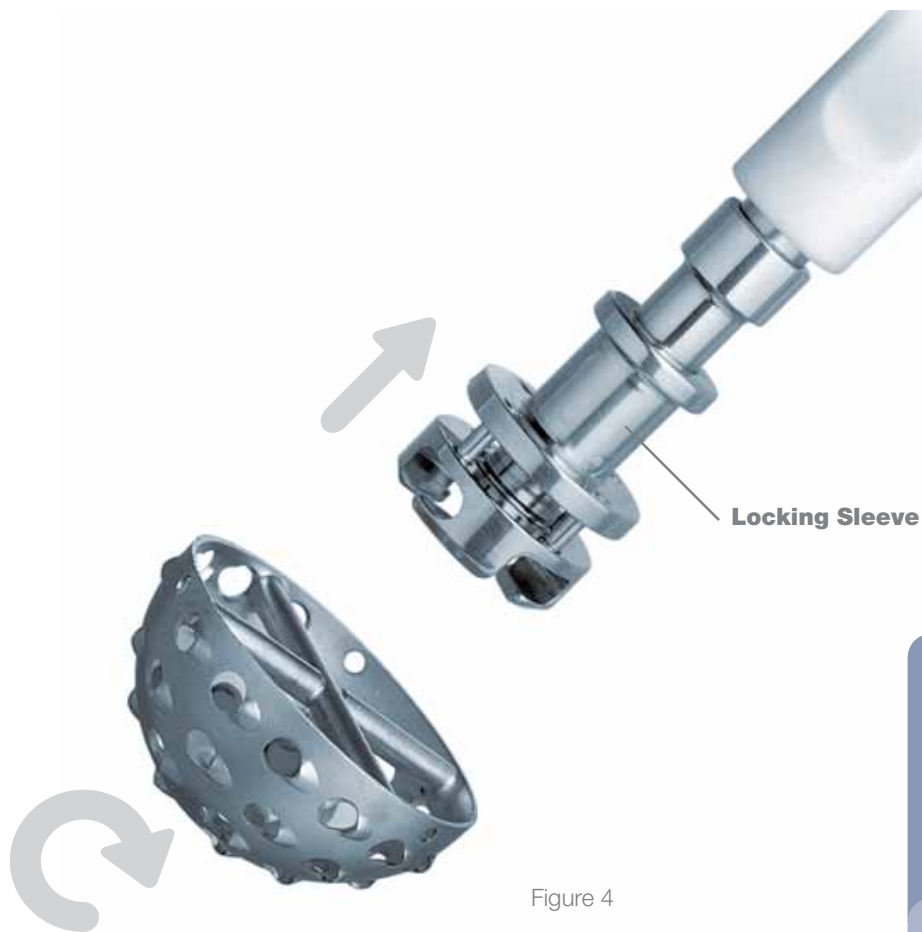

Figure 4

The full profile of the CuttingEdge Spherical Reamer necessitates reaming to the full depth. The reamer head should be driven to the point where the rim/cross bar contacts the acetabular wall at the peripheral lunate region. Removal of the reamer from the handle is performed by pulling back on the locking sleeve and rotating the reamer head a quarter-turn in a clockwise direction (Figure 4).

Care should be taken so as not to enlarge or distort the acetabulum by eccentric reaming. Final acetabular reaming ideally shows the hemispherical acetabulum denuded of cartilage, with the subchondral plate preferably intact, and the acetabular walls preserved.



**TIP**

**William Capello, M.D.**  
 “Pay special attention to differential bone densities that could cause eccentric reaming.”



**NOTE**

The CuttingEdge Spherical Reamers are very aggressive and perform best when sharp. Care should be taken to protect the reamer from unnecessary handling, as dull or damaged cutting teeth may cause improper reaming. Dull cutting teeth will deflect to cut softer bone and resist hard bone. This situation may result in an irregularly shaped or enlarged acetabulum preparation.

# STEP 3B

## FINAL REAMING



### NOTE

The amount of interference fit for Trident and Tritanium acetabular shells should be determined intraoperatively based upon the patient's bone quality.

**Tritanium Solid Back, Cluster and Multi-Hole Shell:**  
*Full surgical technique details for Tritanium Solid Back and Cluster Hole Shells can be found in LSP66. Full surgical technique details for Tritanium Multi-Hole Shells can be found in LSP57.*

When implanting the Tritanium Solid Back, Cluster Hole, or Multi-Hole Shell, it is recommended to under-ream by 1mm. As with all manufacturing processes, due to the nature of the coating, the outer diameter may be slightly larger than the size indicated. The surgeon should consider this during acetabular preparation. Depending on acetabular bone quality, the surgeon may choose to ream line-to-line.



### NOTE

When osteoporotic bone is encountered, it is recommended to under-ream by 1mm. When sclerotic bone is encountered, it may be difficult to fully seat the shell with a 1mm interference fit. In this situation, it is recommended to ream 1mm under, or line-to-line to reduce the potential for problems that may typically occur in dense bone. Potential challenges implanting acetabular shells may include: acetabular fracture, failure to fully seat the implant or slight deformation of the titanium shell, making seating the insert more difficult.



### TIPS

**Timothy Izant, M.D.**  
"Assess patient bone quality prior to implantation. If patient possesses hard, type A bone, line-to-line reaming is recommended. If proper bone quality exists, it is advised to under-ream by 1mm."

**Trident Hemispherical:**  
*Full surgical technique details can be found in LSP69.*

Under-reaming by 1 to 2 mm of the actual Trident Hemispherical shell size is recommended to achieve interference fit.

**Trident PSL:**  
*Full surgical technique details can be found in LSP68.*

The Trident PSL HA shell periphery is 1.8mm larger than the stated size (e.g., 52mm shell = 53.8mm periphery at the rim of the shell). The size of the Trident PSL HA shell selected should be the same as the largest diameter of the CuttingEdge Spherical Reamer used. Surgical judgment is used to assess bone stock, amount of interference and proper amount of reaming as desired. When implanting the Trident PSL HA shell, the 1.8mm of interference fit is not always necessary when dense, hard, sclerotic bone is encountered.



# STEP 4

## TRIAL EVALUATION



Figure 5



Figure 6

Following the reaming procedure, the appropriate Trident or Tritanium Window Trial (Tables 2-3), of the same diameter as the final implant size, is threaded onto the CuttingEdge Shell Positioner/ Impactor and placed in the acetabulum to evaluate the size and congruity of the preparation (Figure 5). The trial is “windowed” for visualization and assessment of fit, contact and congruency of the trial within the acetabulum. By inserting the appropriate-sized MDM Liner Trial into the Window Trial (Figure 6), joint mechanics can be evaluated. The MDM Liner Trial is designed with two forcep holes in the dome to assist with insertion and removal. The MDM Liner Trial can be inserted and removed manually or with the use of standard forceps. Trial insert and head reduction can be facilitated at this point – please refer to Step 8 for more detailed information.

**TABLE 2: TRIDENT WINDOW TRIAL/ TRIAL LINER SIZING**

WINDOW TRIAL CATALOG NUMBER	TRIDENT WINDOW TRIAL OD (mm)	TRIAL LINER ALPHA CODE
2208-2044A	44	C
2208-2046A	46	D
2208-2048A	48	D
2208-2050A	50	E
2208-2052A	52	E
2208-2054A	54	F
2208-2056A	56	F
2208-2058A	58	G
2208-2060A	60	G
2208-2062A	62	H
2208-2064A	64	H
2208-2066A	66	I
2208-2068A	68	I
2208-2070A	70	J
2208-2072A	72	J

**TABLE 3: TRITANIUM WINDOW TRIAL/TRIAL LINER SIZING**

WINDOW TRIAL CATALOG NUMBER	TRITANIUM WINDOW TRIAL OD (mm)	TRIAL LINER ALPHA CODE
2208-4047	47	C
2208-4048S	48	C
2208-4049	49	D
2208-4050	50	D
2208-4051	51	D
2208-4052S	52	D
2208-4053	53	E
2208-4054	54	E
2208-4055	55	E
2208-4056S	56	E
2208-4057	57	F
2208-4058	58	F
2208-4059	59	F
2208-4060S	60	F
2208-4061	61	G
2208-4062	62	G
2208-4063	63	G
2208-4064S	64	G
2208-4065	65	H
2208-4066	66	H
2208-4067	67	H
2208-4068S	68	H
2208-4069	69	I
2208-4070	70	I
2208-4071	71	I
2208-4072S	72	I
2208-4073	73	J
2208-4074	74	J
2208-4075	75	J
2208-4076	76	J
2208-4077	77	J
2208-4078	78	J
2208-4079	79	J
2208-4080	80	J



**NOTE**

Trident window trials are black and Tritanium window trials are green.

# STEP 5

## SHELL IMPLANTATION

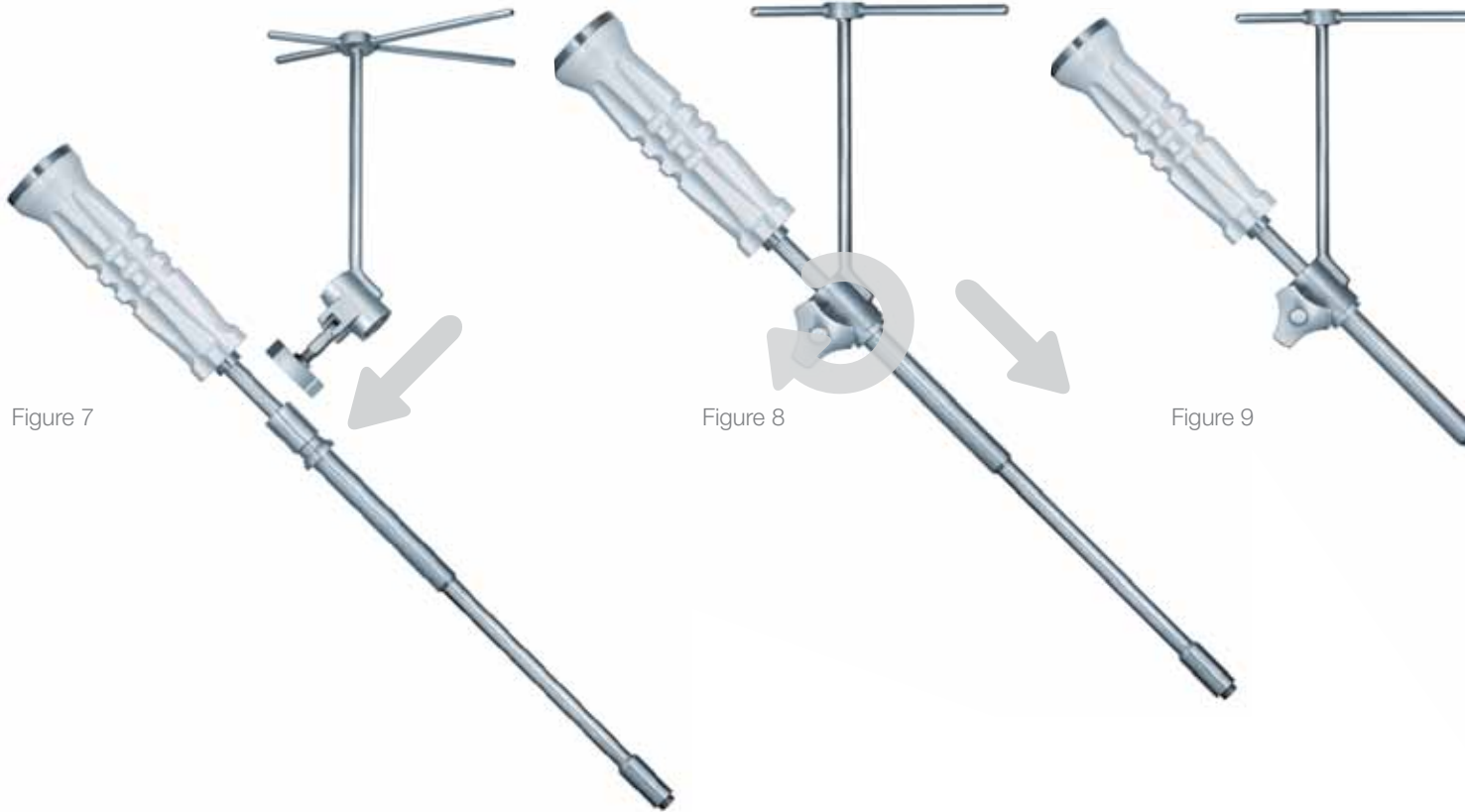

Figure 7

Figure 8

Figure 9

After completing the trial reduction, select the appropriately-sized Trident or Tritanium Acetabular Shell as clearly identified on the product label. Ensure the patient is in the correct position. At this step it is prudent to reassess patient positioning in the surgical field. If desired, the CuttingEdge Abduction/Anteversion Alignment Guide can be attached to the CuttingEdge Shell Positioner/Impactor to help establish the recommended 45° of abduction/inclination and 20° of anteversion (Figures 7 and 8).

Assess acetabulum and surrounding soft tissue prior to shell introduction to ensure nothing is preventing shell implantation. During shell introduction into the acetabulum, minimize damage to the shell coating by instrumentation such as retractors, and avoid dragging the roughened surface across soft tissue.



### CAUTION

The Alignment Guide may yield inaccurate placement if the pelvis has moved from the original position during intraoperative manipulation. Small changes in pelvic flexion will greatly affect anteversion. The Alignment Guide is only one aid to assist with proper implant positioning. The surgeon must also rely on anatomic landmarks to avoid improper positioning of components.



### NOTE

Proper positioning of the Trident or Tritanium Acetabular Shell will minimize potential impingement and provide optimal stability and articulation between the Insert and Head. As with any acetabular system, excessive vertical orientation and/or anteversion of the shell should be avoided as this may lead to premature wear of the insert material.

The Trident or Tritanium acetabular shell is threaded onto the impactor at the threaded hole in the dome of the metal shell. It is important to fully engage the threads and seat the impactor against the shell. Failure to fully engage the threads and seat the impactor could result in thread damage and subsequent difficulty removing the impactor from the shell. If the cluster screw hole pattern shell is utilized, the holes are intended to be oriented superiorly (Figure 9).

Figure 10  
A/P View

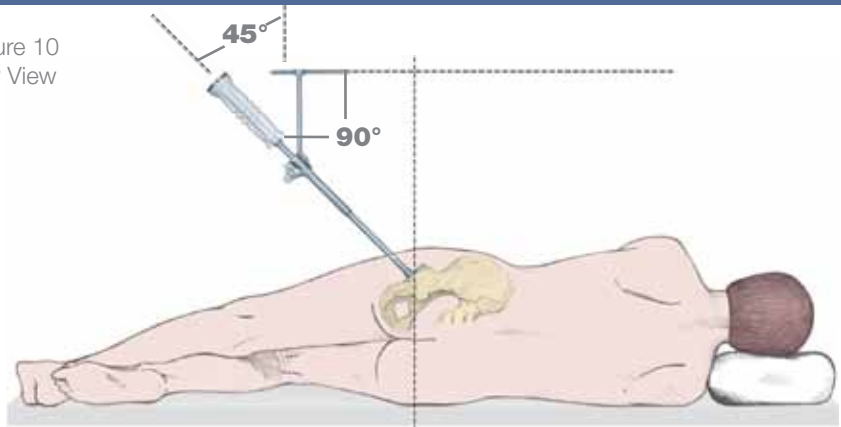
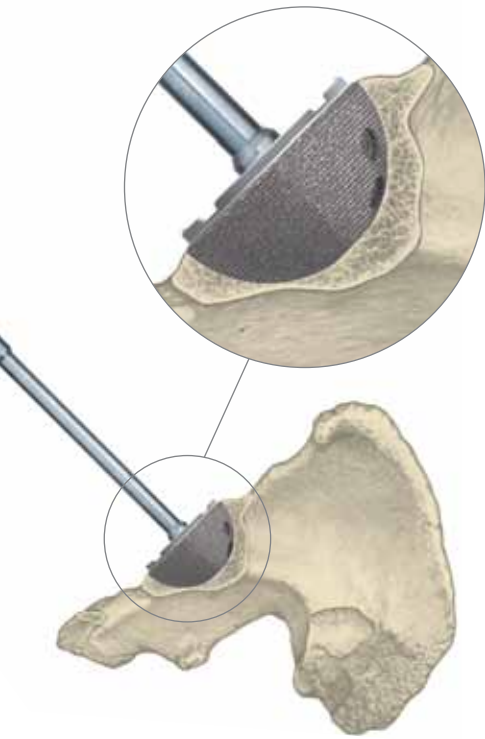
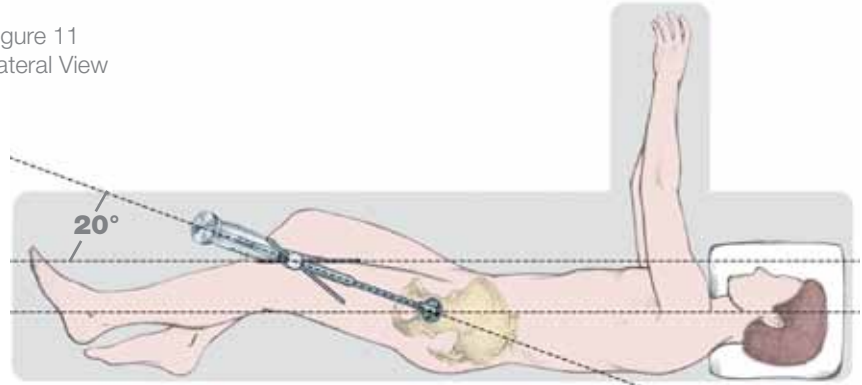

Figure 11  
Lateral View



The recommended metal shell abduction angle of  $45^\circ$  is determined by positioning the alignment guide perpendicular to the long axis of the patient (Figure 10). Metal shell anteversion is set at approximately  $20^\circ$  by moving the cup impactor so that the left/right anteversion rod is parallel to the long axis of the patient (Figure 11). The metal shell is impacted into the acetabulum using a mallet until a tight, stable, press-fit is achieved. The thumbscrew on the alignment guide is then loosened to remove the guide. After removing the guide, the impactor handle is carefully unthreaded from the shell.

The depth of the shell seating may now be determined by viewing through the threaded hole in the dome. If it is determined that the shell is not fully seated, the CuttingEdge Final Cup Impactor may then be required to assist in impacting the shell until it is completely seated in the prepared acetabulum. If utilizing the optional dome hole plug, assess that the plug is fully threaded into the shell to prevent liner impingement.



#### TIP

**William Capello, M.D.**

**“With any high friction interface, the potential for the cup to change position during insertion is possible due to differential bone densities. Care should be taken to monitor position so that changes can be made as necessary.”**

**“While the alignment guides are of some assistance, it is important to critically evaluate anatomic landmarks before placement of the acetabular component. These anatomic landmarks include the anterior and posterior walls of the acetabulum, the sciatic notch, the floor and/or acetabular fossa of the acetabulum.”**

# STEP 5A

## OPTIONAL SCREW UTILIZATION

If implanting a cluster hole shell with screws, then only Stryker Orthopaedics Bone Screws can be used. Torx Bone Screws (2030-65XX-1) are compatible with Trident Hemispherical, Trident PSL, and Tritanium Cluster Hole shells (Table 4, Figure 12). Hex Bone Screws (5260-5-XXX) and Torx (2080-00XX) are only compatible with Tritanium Multi-hole shells (Table 5, Figure 12 and 13). Stryker Orthopaedics offers 6.5mm diameter cancellous bone screws which are available in a variety of lengths. Stryker Orthopaedics Cancellous Bone Screws are designed to be inserted or removed only with the assistance of Stryker Orthopaedics screw instruments.



### CAUTION

Do not use Stryker Torx Bone Screws (2030-65XX-1) with Tritanium Multi-Hole Shells.

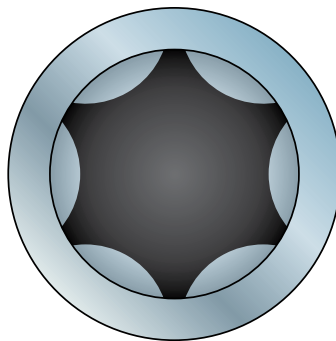

Figure 12  
Torx® Drive Head

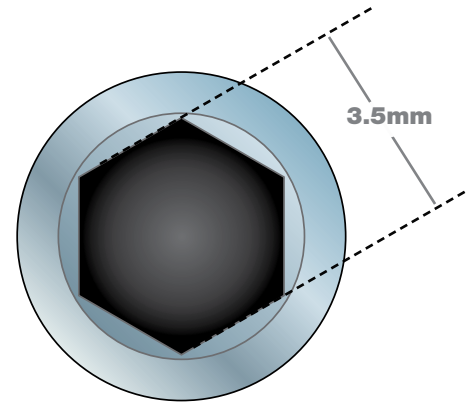

Figure 13  
3.5mm Hex Drive Head

**TABLE 4:** Stryker Torx 6.5mm Bone Screws for use with Trident Hemispherical, Trident PSL, and Tritanium Cluster Hole Shells

CATALOG NUMBER	SCREW LENGTHS (mm)
2030-6516-1	16
2030-6520-1	20
2030-6525-1	25
2030-6530-1	30
2030-6535-1	35
2030-6540-1	40
2030-6545-1	45
2030-6550-1	50
2030-6555-1	55
2030-6560-1	60

**TABLE 5:** Stryker Hex and Torx 6.5mm Bone Screws for use with Tritanium Multi-Hole Shells

TOREX SCREW CATALOG NUMBER	SCREW LENGTHS (mm)	HEX SCREW CATALOG NUMBER	SCREW LENGTHS (mm)
2080-0015	15	5260-5-012	12
2080-0020	20	5260-5-014	14
2080-0025	25	5260-5-016	16
2080-0030	30	5260-5-018	18
2080-0035	35	5260-5-020	20
2080-0040	40	5260-5-022	22
2080-0045	45	5260-5-024	24
2080-0050	50	5260-5-026	26
2080-0055	55	5260-5-028	28
2080-0060	60	5260-5-030	30
		5260-5-035	35
		5260-5-040	40
		5260-5-045	45
		5260-5-050	50

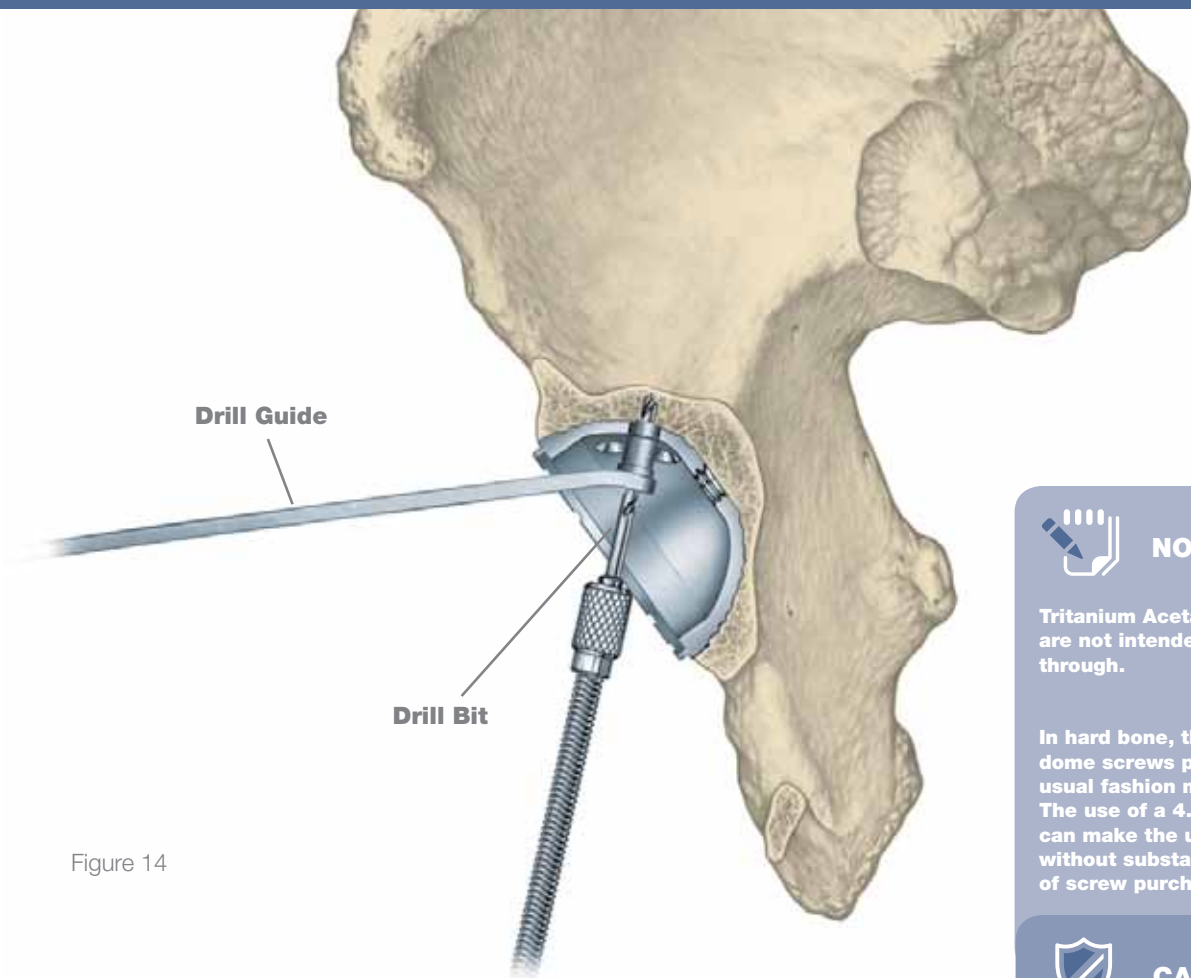

Figure 14

After determination of the proper site for screw placement, a 3.3mm (Trident Hemispherical, Trident PSL, and Tritanium Cluster Hole) or 3.2mm (Tritanium Multi-Hole) diameter drill is passed through a drill guide to the desired depth (Figure 14). It is important to use the proper drill guide to keep the pilot hole as straight as possible so that the screw head fully seats. With Trident and Tritanium Cluster Hole Shells, the proper drill guide is 2107-3317 and with Tritanium Multi-Hole the proper drill guide is 6060-5-310 or 6060-5-300. The depth of the hole is then assessed using a depth gauge. The properly-sized screw is then selected and implanted into the bone using Stryker Orthopaedics Screw Drivers with a high torque configuration driver head (Figure 12 and 13). After screw implantation, assess that the screw head is seated flush against the shell to prevent improper seating of the MDM Liner.



#### NOTE

Tritanium Acetabular shells are not intended to be drilled through.

In hard bone, the use of 6.5mm dome screws prepared in the usual fashion may be difficult. The use of a 4.0mm drill bit can make the utilization easier without substantial compromise of screw purchase.



#### CAUTION

Do not pass a drill, screw or any other instrumentation beyond the inner table of the pelvis. Malposition of either the shell screw hole orientation, screw hole preparation or improper use of the screws themselves may contribute to detrimental clinical consequences.

Do not apply torque in excess of 69 in-lbs. to the screw. This may result in damage to the screw or driver instrument. To reach 69 in-lbs. unnecessary excessive force has to be applied. Power driven screw inserters may exceed 69 in-lbs.

# STEP 6

## TRIAL INSERT REDUCTION

After metal shell implantation, the MDM Trial Liner provides a final check of hip biomechanics.

# STEP 7

## LINER IMPLANTATION



Figure 15



Figure 16

1. Ensure that the inside of the shell is clean, dry and free of soft tissue or any other debris, which could prevent the liner from properly seating in the shell.
2. Gently introduce the MDM Liner making sure that the liner flange scallops are aligned with the Removal Tool Slots at the rim of the shell (Figure 15). This orientation will allow the liner to rest on the four indexing bars and will ensure that the liner is parallel with the shell. Next, slowly turn the liner until it drops into the final pre-locking position. Correct rotational orientation will result in the Liner Tabs aligned with the Removal Tool Slots (Figure 16).

Apply finger pressure around the rim of the liner first to engage the liner within the shell. It may then be necessary to lightly tap on the rim of the liner with the final cup impactor handle (2101-0130 – Figure 17), working around the rim in all four quadrants, to ensure the liner is properly seated in the shell. The liner is properly seated when there is no further rocking or movement of the liner within the shell. This step should be done prior to final impaction of the liner.



### NOTE

Having a clear view of the rim of the acetabulum will allow easier visualization of the shell's slot and indexing bars for proper positioning and seating of the liner.



### CAUTION

Care should be taken to avoid damage to the highly polished inner surface of the MDM CoCr Liner.

Care should be taken to ensure that the liner is correctly aligned within the shell. Failure to do so may result in incomplete or incorrect liner engagement.

# STEP 7

## LINER IMPLANTATION *CONTINUED*

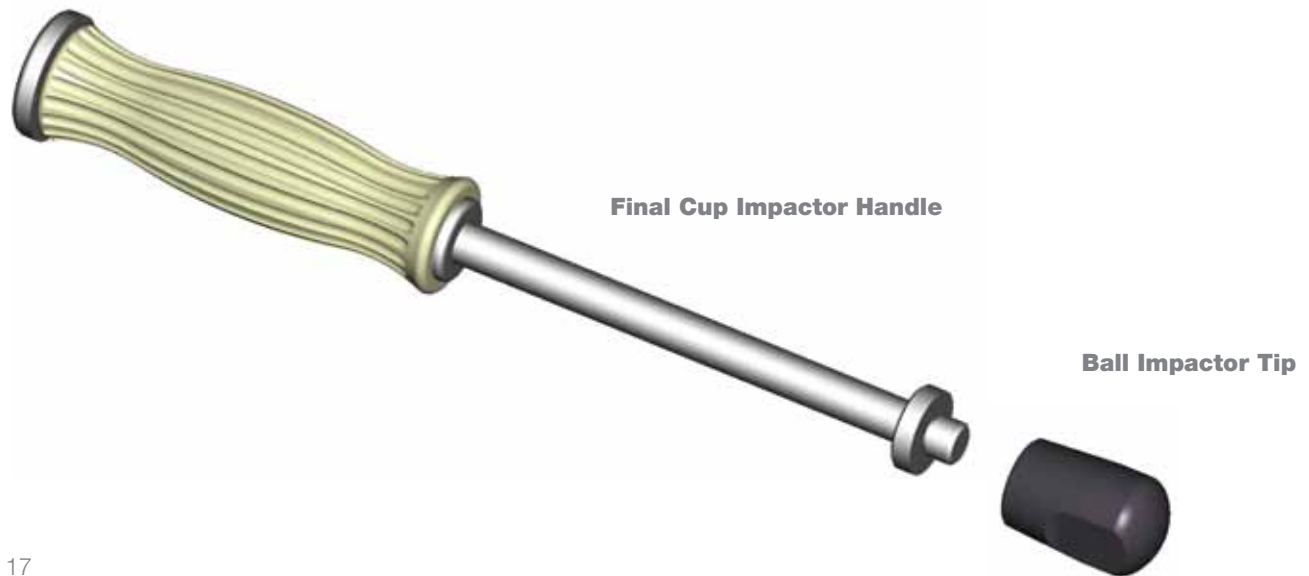

Figure 17

3. Select the ball impactor tip (1235-0-013) and assemble to the Final Cup Impactor Handle (2101-0130). The Final Cup Impactor Handle comes pre-assembled with a blunt tip. Please unscrew the tip in order to assemble the ball impactor tip. Ensure the ball impactor tip is threaded tightly onto the impactor handle (Figure 17). Strike the handle with approximately four mallet blows to fully seat the liner using the slotted mallet (1120-1000).
4. Verify liner is properly aligned and fully seated into the acetabular shell (Figure 16). Check the taper lock by running a small blunt instrument (or the liner removal tool, 2112-0000) around the periphery of the shell/liner interface. There should not be any space between the rim of the shell and the under side of the liner rim.
5. Visually assess the inner articular surface of the MDM Liner to ensure it is not scratched or damaged prior to the trial insert/head reduction.



### NOTE

As with any modular interface under load, there is a potential for fretting and/or corrosion. Proper alignment and locking of the MDM liner into the Trident or Titanium shell may help to minimize this risk.



### NOTE

The ball impactor tip has a limited life expectancy; deformation is expected and should be checked before each use. The instrument must be changed if deformation or cracks are visible. Periodic replacement is required.

# STEP 8

## TRIAL INSERT/HEAD REDUCTION

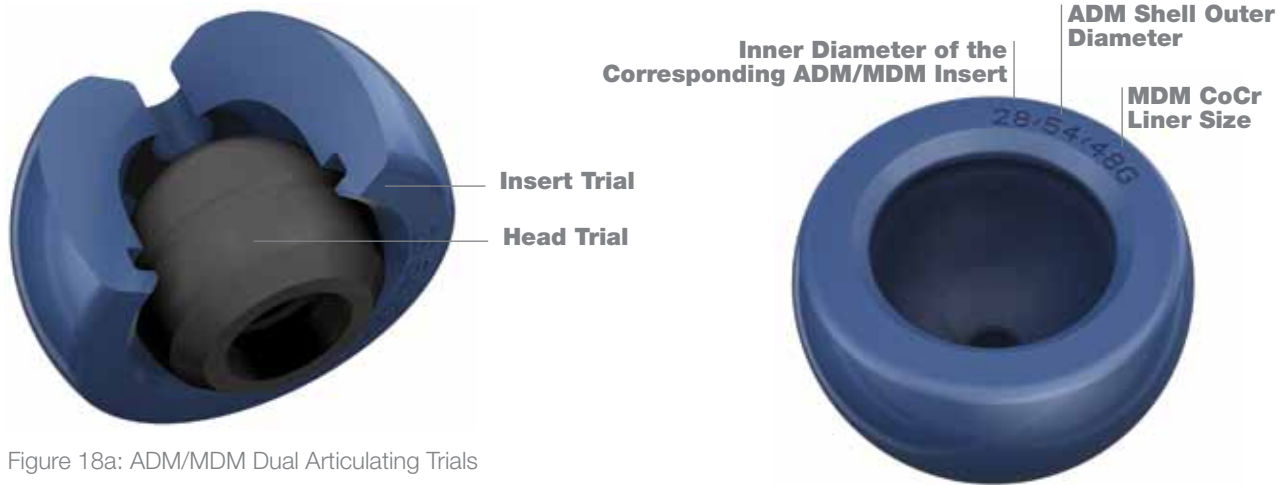

Figure 18a: ADM/MDM Dual Articulating Trials

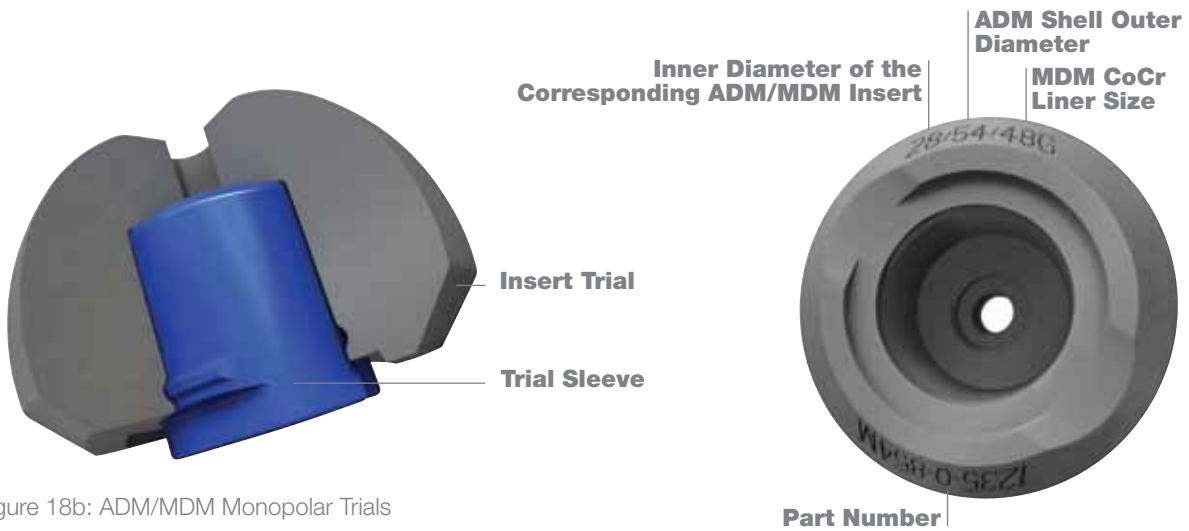

Figure 18b: ADM/MDM Monopolar Trials

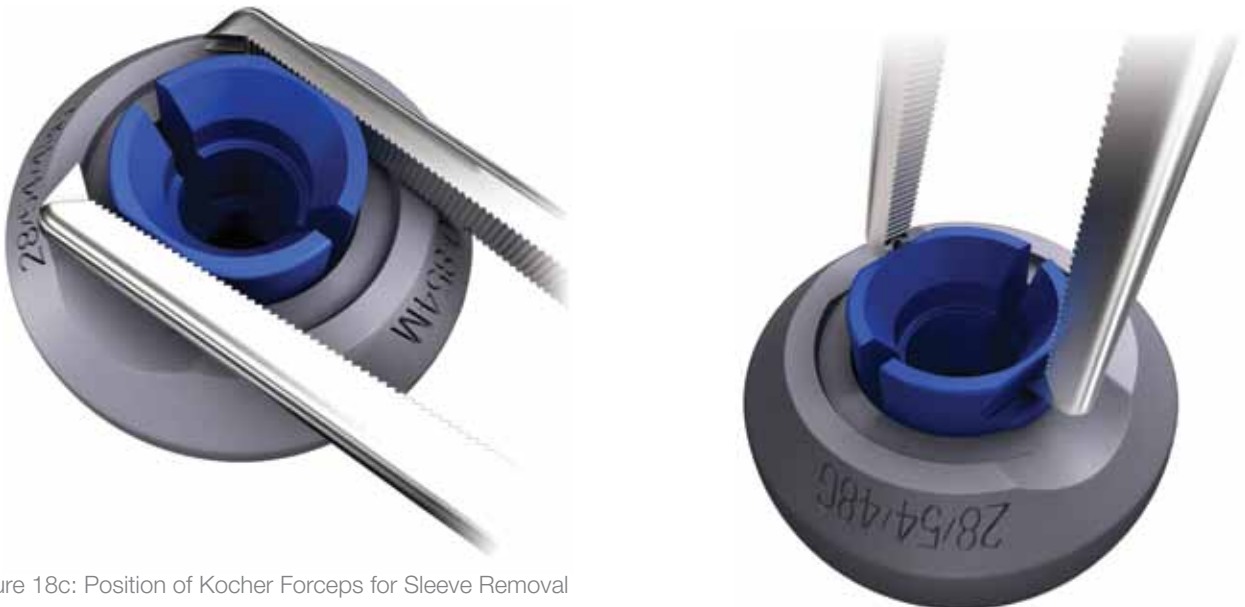

Figure 18c: Position of Kocher Forceps for Sleeve Removal



- After shell and MDM Liner implantation, there is an option to use either the ADM/MDM Dual Articulating Trials or the ADM/MDM Monopolar Trials. Both trialing options will facilitate a final check of hip mechanics to include range of motion consistent with the patient's normal daily activities. At this point, joint laxity should also be assessed, taking into consideration the type of anesthetic used and its effects on soft tissue.
- If using the ADM/MDM Dual Articulating Trials, place the 22.2mm or 28mm Head Trial into the appropriate Insert Trial to mimic the final articulation function of the MDM System (Figure 18a). The size of the insert trial will correspond with the MDM Liner being implanted (Table 6).
- If using the ADM/MDM Monopolar Trials, place the Trial Sleeve that corresponds to the desired femoral head taper and offset into the appropriate Insert Trial by firmly pushing the Sleeve into the inner geometry of the Insert Trial (Figure 18b, Tables 6-8). Correct assembly of the Trial Sleeve and Insert Trials will produce an audible click. The size of the Insert Trial will correspond with the MDM liner being implanted (Tables 6-8).
- Place the assembled Dual Articulating or Monopolar Trials onto the neck trial or stem trunnion component. Ensure that the Monopolar Trials are locked by firmly pushing the Insert Trial-Sleeve assembly onto the neck trial or stem. Reduce the hip, checking for hip stability and the restoration of leg length. Fine tuning of hip joint mechanics may be achieved with the use of different +/- offsets.
- Once hip stability and leg length have been checked, the Dual Articulating or Monopolar Trial assembly can be removed from the neck trial or trunnion as one unit. If using the Monopolar Trials, the Trial Sleeve can then be removed from the Insert Trial with the assistance of standard Kocher forceps by squeezing the Trial Sleeve and pulling it out of the Insert Trial (Figure 18c). This can also be accomplished by hand.



## NOTE

The Monopolar Trials are only available for V40 and C-Taper heads. Additionally, a feature has been included in the Monopolar Trial design to prevent the assembly of Trial Sleeve offsets only available in 28mm heads into 36C and 38D Insert Trials. The Monopolar Trials are marked 'trial do not implant'. If there is any reason to believe that the trial has been accidentally implanted, the Monopolar Insert Trial is radiopaque and would be visible on an X-Ray.



## NOTE

When using dual mobility implants, impingement should be carefully assessed and avoided during range of motion. Impingement can result in increased wear in metal-polyethylene systems.



## TIPS

**Paul Perona, M.D.**  
When using the ADM/MDM Dual Articulating Trials, place the 22.2mm or 28mm trial head onto the neck trial or stem trunnion and place the ADM/MDM Insert Trial into the MDM Liner. The smaller trial head can then be reduced into the Insert Trial for ease of reduction.

**TABLE 6:** MDM Liner, Insert and Femoral Head Compatibility

MDM LINER	MDM LINER TRIAL	ADM/MDM X3 INSERT	ADM/MDM DURATION INSERT	ADM/MDM DUAL ARTICULATING INSERT TRIAL	REQUIRED FEMORAL HEAD SIZE (MM)	ADM/MDM MONOPOLAR INSERT TRIAL
626-00-36C	3200-36C	1236-2-242	—	1235-0-242	22.2 mm	1235-0-242M
626-00-38D	3200-38D	1236-2-244	—	1235-0-244	22.2 mm	1235-0-244M
626-00-42E	3200-42E	1236-2-848	1235-2-848	1235-0-848	28 mm	1235-0-848M
626-00-46F	3200-46F	1236-2-852	1235-2-852	1235-0-852	28 mm	1235-0-852M
626-00-48G	3200-48G	1236-2-854	1235-2-854	1235-0-854	28 mm	1235-0-854M
626-00-52H	3200-52H	1236-2-858	1235-2-858	1235-0-858	28 mm	1235-0-858M
626-00-54I	3200-54I	1236-2-860	1235-2-860	1235-0-860	28 mm	1235-0-860M
626-00-58J	3200-58J	1236-2-864	1235-2-864	1235-0-864	28 mm	1235-0-864M

**Note:** Inserts are compatible with Stryker 22.2 and 28mm heads only.



## NOTE

With the launch of the monopolar trials, all trays moving forward will have the same catalog number (1235-0-306) along with updated markings to provide guidance on the monopolar trial placement. You will be able to distinguish between an original tray and a new tray as the original will not call out the 'M' in the Insert Trial catalog number. Additionally, the 'Sleeve' Trials will not be specified on the tray.

If a tray is being used that was launched prior to the monopolar trials, the following guidelines must be followed:

- The new monopolar insert trials (1235-0-XXXXM) fit in the same location as the dual articulating insert trials (1235-0-X XX). The new monopolar sleeve trials (1235-V-XXXX and 1235-C-XXXX) fit on the same posts marked as head trials.

# STEP 8

## TRIAL INSERT/HEAD REDUCTION *CONTINUED*

**TABLE 7:** Monopolar Trial Sleeve Catalog Numbers and V40 22.2 and 28mm Femoral Head Options

V40 22.2MM FEMORAL HEAD OFFSETS	MONOPOLAR TRIAL SLEEVE	LFIT COCR			
+0mm	1235-V-1000	✓			
+3mm	1235-V-1030	✓			
+8mm	1235-V-1080	✓			

V40 28MM FEMORAL HEAD OFFSETS	MONOPOLAR TRIAL SLEEVE	LFIT COCR	BIOLOX <i>delta</i>	BIOLOX <i>delta</i> UNIVERSAL	ALUMINA
-4mm	1235-V-0040	✓	✓		
-2.7mm	1235-V-0027		✓		✓
-2.5mm	1235-V-0025			✓	
+0mm	1235-V-1000	✓	✓	✓	✓
+4mm	1235-V-1040	✓	✓	✓	✓
+6mm	1235-V-1060	✓			
+8mm	1235-V-1080	✓			
+12mm	1235-V-1120	✓			

**TABLE 8:** Monopolar Trial Sleeve Catalog Numbers and C-Taper 22.2 and 28mm Femoral Head Options

C-TAPER 22.2MM FEMORAL HEAD OFFSETS	MONOPOLAR TRIAL SLEEVE	LFIT COCR			
+0mm	1235-C-1000	✓			
+2.5mm	1235-C-1025	✓			
+5mm	1235-C-1050	✓			
+10mm	1235-C-1100	✓			

C-TAPER 28MM FEMORAL HEAD OFFSETS	MONOPOLAR TRIAL SLEEVE	LFIT COCR	BIOLOX <i>delta</i>	BIOLOX <i>delta</i> UNIVERSAL	ALUMINA
-3mm	1235-C-0030	✓			
-2.5mm	1235-C-0025		✓	✓	✓
+0mm	1235-C-1000	✓	✓	✓	✓
+2.5mm	1235-C-1025	✓	✓	✓	
+5mm	1235-C-1050	✓	✓	✓	✓
+7.5mm	1235-C-1075	✓			
+10mm	1235-C-1100	✓			

# STEP 9

## INSERT/HEAD IMPLANTATION

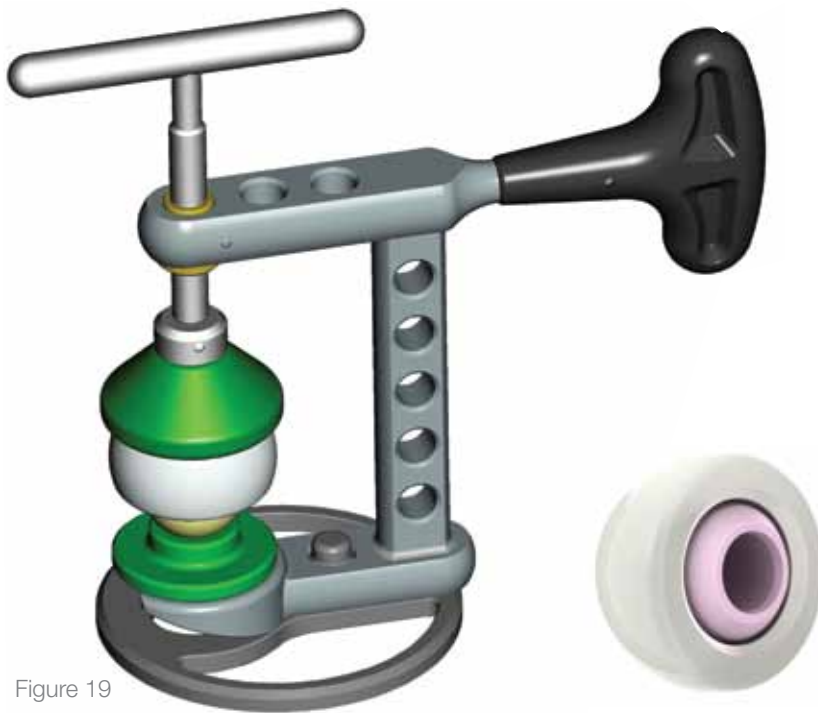

Figure 19

Back table assembly of the Insert and corresponding V40 or C-Taper 22.2mm\* or 28mm Head is required (Figure 19). The following instructions must be carefully adhered to:

- Place the Press Stand flat on the table and place the Press onto the Press Stand Pin.
- Put the Femoral Head Supporting Piece into the base of the Press as shown above.
- Open the press by turning the T-handle counter-clockwise until the polyethylene insert fits above the femoral head and below the plastic cone portion of the press.
- Place the Femoral Head onto the Head Supporting Piece and then place the Insert onto the Femoral Head.
- Once the Femoral Head and polyethylene insert are in a vertical position, tighten the Press until the head is fully lodged into the insert. After insertion, the air confined between the head and insert is usually released, resulting in a characteristic noise.
- After the head and insert are assembled, verify that the coupling has complete mobility.

\*Stryker Universal, V40 and C-Taper BIOLOX delta and Alumina Ceramic heads are not available in 22.2mm. They can only be utilized in inserts compatible with 28mm heads.



Head Supporting Piece



### NOTE

Ensure that the inside of the shell is clean and free of soft tissue or other debris, which could prevent the polyethylene insert from properly seating in the shell.



### WARNING

A metal or ceramic head should not be used in place of the dual mobility insert/head. The MDM Liner is not intended for use as a metal-on-metal or ceramic-on-metal articulation. No testing has been conducted to determine that these bearing couples produce favorable mechanical outcomes. Only Stryker 22.2mm or 28mm femoral heads should be inserted into the ADM/MDM polyethylene inserts.

# STEP 10

## REDUCTION AND CLOSURE

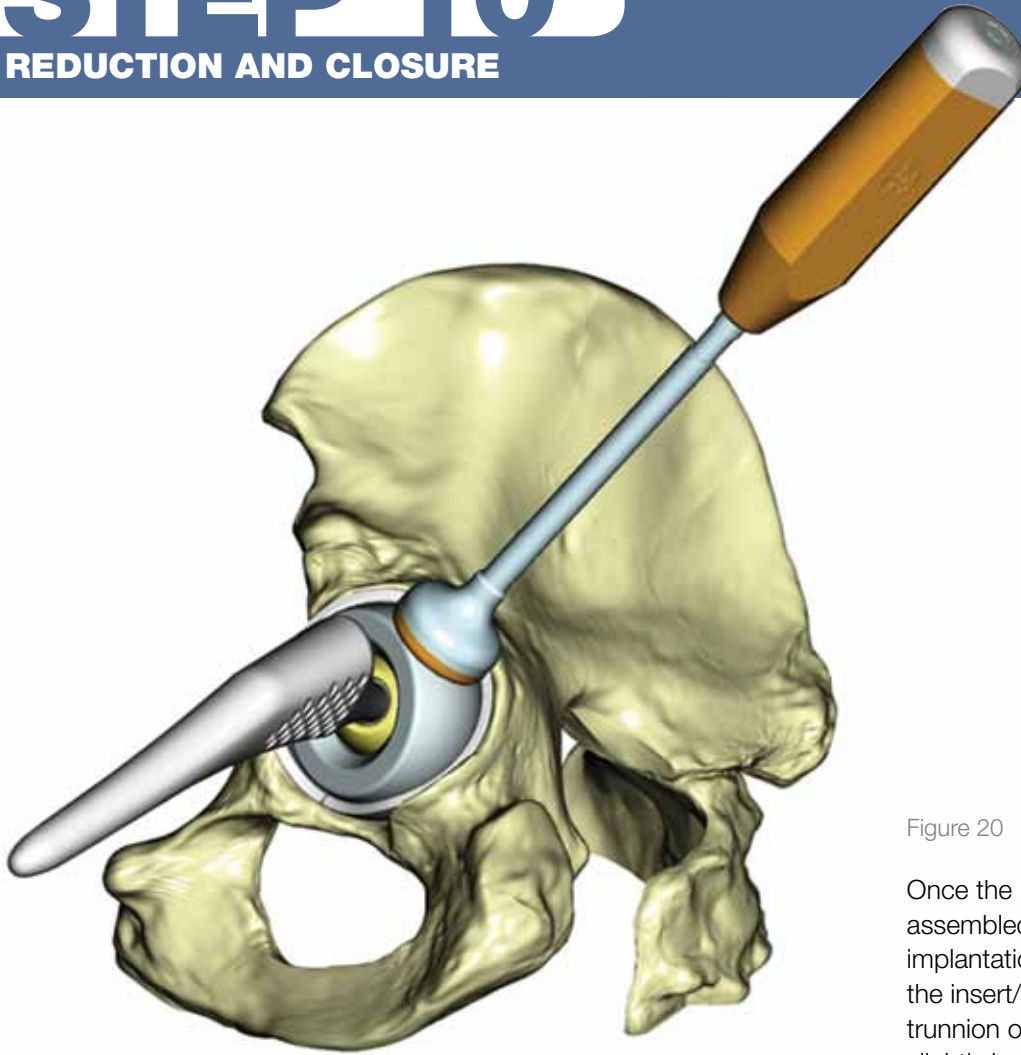

Figure 20

Once the Insert and Head are assembled, the unit is ready for implantation and reduction. Place the insert/head unit onto the trunnion of the femoral stem and slightly impact with Insert Reduction Tool (1235-0-020). Then, by exerting axial traction on the limb and pressure on the insert using the insert reduction tool, reduce the hip and check for laxity, stability, leg length equality and range of motion (Figure 20). The surgical site is then closed according to surgeon preference.



### CAUTION

Care should be taken to avoid damage to the polyethylene insert during reduction as this may lead to premature wear of the insert material.

# REMOVAL

## LINER SHELL, INSERT/HEAD

### MDM Liner Removal

**The Trident Insert Removal Tool is designed to provide the surgeon with two options for extracting the MDM Liner from the Trident or Tritanium shell.**



Figure 21

#### Option 1: “Flat Head”

Connect the “T” handle to the L-shaped end of the removal tool. Insert the flat end of the removal tool between the shell and MDM Liner at one of the four notches in the shell rim (Figure 21). While applying continuous force toward the center of the shell, twist the “T” handle (like a screwdriver), to dislodge the MDM Liner. Bias the flat head of the tool toward the left when rotating the instrument in a counter-clockwise direction to improve its effectiveness. Conversely, biasing the tool toward the right when rotating clockwise may aid in its use. It may be required to repeat this procedure at the other notches in order to successfully disengage the taper.



#### NOTE

Prior to performing a liner exchange, visually assess the shell's locking mechanism for damage. If damaged, shell should be replaced.



Figure 22

#### Option 2: “L-Shaped”

Insert the L-shaped end of the removal tool between the shell and MDM Liner at one of the four notches in the shell rim (Figure 22). Apply continuous force toward the center of the shell, and lever the tool in a plane tangent to the shell's outside edge, to dislodge the MDM Liner. It may be required to repeat this procedure at the other notches in order to successfully disengage the taper. The removal tool may be attached to the Insert Positioner/ Impactor Handle to increase leverage and length for larger patients.

### Shell Removal

Should removal of the metal shell ever become necessary, an osteotome or small burr can be passed around the cup periphery to loosen the fixation interface. The CuttingEdge Universal Shell Positioner can be threaded into the dome hole of the cup. A Slotted Mallet is slid over the positioner shaft to assist with the shell removal.

### Insert/Head Unit Removal



#### NOTE

Once the polyethylene insert and femoral head are assembled, the two components cannot be disassembled. However, the assembled polyethylene insert and femoral head unit can be removed from the trunnion of the stem. If the insert and head unit needs to be revised for any reason, remove the unit with the Femoral Head Remover Instrument (6059-9-505 - Figure 23).

- Place distal portion of the femoral head remover instrument over the neck of the stem, while placing the proximal portion of the instrument under the insert and head unit.
- Once the instrument is in position, squeeze the handles together to pry the insert and head unit off of the trunnion of the stem.
- Be sure that the instrument is not pressing against the outer bearing surface of the poly, as this will decrease the effectiveness of the removal tool and will result in a significantly larger force required to separate the head from the stem.



Figure 23

# MDMX3

## CATALOG INFORMATION

### MDM Liner, Insert and Femoral Head Compatibility

MDM LINER	MDM LINER TRIAL	ADM/MDM X3 INSERT	ADM/MDM DURATION INSERT	ADM/MDM DUAL ARTICULATING INSERT TRIAL	REQUIRED FEMORAL HEAD SIZE (MM)	ADM/MDM MONOPOLAR INSERT TRIAL
626-00-36C	3200-36C	1236-2-242	—	1235-0-242	22.2 mm	1235-0-242M
626-00-38D	3200-38D	1236-2-244	—	1235-0-244	22.2 mm	1235-0-244M
626-00-42E	3200-42E	1236-2-848	1235-2-848	1235-0-848	28 mm	1235-0-848M
626-00-46F	3200-46F	1236-2-852	1235-2-852	1235-0-852	28 mm	1235-0-852M
626-00-48G	3200-48G	1236-2-854	1235-2-854	1235-0-854	28 mm	1235-0-854M
626-00-52H	3200-52H	1236-2-858	1235-2-858	1235-0-858	28 mm	1235-0-858M
626-00-54I	3200-54I	1236-2-860	1235-2-860	1235-0-860	28 mm	1235-0-860M
626-00-58J	3200-58J	1236-2-864	1235-2-864	1235-0-864	28 mm	1235-0-864M

**Note: Inserts are compatible with Stryker 22.2 and 28mm heads only.**

CATALOG NUMBER	DESCRIPTION
5900-8114	MDM Case
1235-0-306	MDM Tray
1235-0-020	Insert Reduction Tool
1235-0-008	Press
1235-0-012	Press Stand
1235-0-009	Head Supporting Piece
2112-0000	CoCr Liner Removal Tool
1235-0-013	Ball Impactor Tip



### Tritanium Window Trial /Trial Liner Sizing

CATALOG NUMBER	DESCRIPTION
2402-4041	Tritanium Window Trials Top Tray (Sizes 43mm-67mm)
2402-4061	Tritanium Window Trials Bottom Tray (Sizes 68mm-80mm)
2402-4020	Tritanium Window Trials Case
2402-3090	Clear Lid Tray

WINDOW TRIAL CATALOG NUMBER	TRITANIUM WINDOW TRIAL OD (mm)	TRIAL LINER ALPHA CODE
2208-4047	47	C
2208-4048S	48	C
2208-4049	49	D
2208-4050	50	D
2208-4051	51	D
2208-4052S	52	D
2208-4053	53	E
2208-4054	54	E
2208-4055	55	E
2208-4056S	56	E
2208-4057	57	F
2208-4058	58	F
2208-4059	59	F
2208-4060S	60	F
2208-4061	61	G
2208-4062	62	G
2208-4063	63	G
2208-4064S	64	G
2208-4065	65	H
2208-4066	66	H
2208-4067	67	H
2208-4068S	68	H
2208-4069	69	I
2208-4070	70	I
2208-4071	71	I
2208-4072S	72	I
2208-4073	73	J
2208-4074	74	J
2208-4075	75	J
2208-4076	76	J
2208-4077	77	J
2208-4078	78	J
2208-4079	79	J
2208-4080	80	J

### Tritanium Solid Back Shell

CATALOG NUMBER	SHELL SIZE (mm)	RIM DIAMETER (mm)
500-03-48C	48	48
500-03-50D	50	50
500-03-52D	52	52
500-03-54E	54	54
500-03-56E	56	56
500-03-58F	58	58
500-03-60F	60	60
500-03-62G	62	62
500-03-64G	64	64
500-03-66H	66	66

### Tritanium Cluster Hole Shell

CATALOG NUMBER	SHELL SIZE (mm)	RIM DIAMETER (mm)
502-03-48C	48	48
502-03-50D	50	50
502-03-52D	52	52
502-03-54E	54	54
502-03-56E	56	56
502-03-58F	58	58
502-03-60F	60	60
502-03-62G	62	62
502-03-64G	64	64
502-03-66H	66	66

### Tritanium Multi-Hole Shell

CATALOG NUMBER	SHELL SIZE (mm)	RIM DIAMETER (mm)
509-02-54E	54	54
509-02-56E	56	56
509-02-58F	58	58
509-02-60F	60	60
509-02-62G	62	62
509-02-64G	64	64
509-02-66H	66	66
509-02-68H	68	68
509-02-70I	70	70
509-02-72I	72	72
509-02-74J	74	74
509-02-76J	76	76
509-02-78J	78	78
509-02-80J	80	80

### Trident Hemispherical Solid Black Shells

CATALOG NUMBER	SHELL SIZE (mm)	RIM DIAMETER (mm)	WINDOW TRIAL CATALOG NO.
500-01-46C	46	46	2208-2046A
500-01-48D	48	48	2208-2048A
500-01-50D	50	50	2208-2050A
500-01-52E	52	52	2208-2052A
500-01-54E	54	54	2208-2054A
500-01-56F	56	56	2208-2056A
500-01-58F	58	58	2208-2058A
500-01-60G	60	60	2208-2060A
500-01-62G	62	62	2208-2062A
500-01-64H	64	64	2208-2064A
500-01-66H	66	66	2208-2066A
500-01-68I	68	68	2208-2068A
500-01-70I	70	70	2208-2070A
500-01-72J	72	72	2208-2072A
500-01-74J	74	74	2208-2074A

### Trident Hemispherical Cluster Shells

CATALOG NUMBER	SHELL SIZE (mm)	RIM DIAMETER (mm)	WINDOW TRIAL CATALOG NO.
502-01-46C	46	46	2208-2046A
502-01-48D	48	48	2208-2048A
502-01-50D	50	50	2208-2050A
502-01-52E	52	52	2208-2052A
502-01-54E	54	54	2208-2054A
502-01-56F	56	56	2208-2056A
502-01-58F	58	58	2208-2058A
502-01-60G	60	60	2208-2060A
502-01-62G	62	62	2208-2062A
502-01-64H	64	64	2208-2064A
502-01-66H	66	66	2208-2066A
502-01-68I	68	68	2208-2068A
502-01-70I	70	70	2208-2070A
502-01-72J	72	72	2208-2072A
502-01-74J	74	74	2208-2074A

### Trident Hemispherical HA Solid Back Shells

CATALOG NUMBER	SHELL SIZE (mm)	RIM DIAMETER (mm)	WINDOW TRIAL CATALOG NO.
500-11-46C	46	46	2208-2046A
500-11-48D	48	48	2208-2048A
500-11-50D	50	50	2208-2050A
500-11-52E	52	52	2208-2052A
500-11-54E	54	54	2208-2054A
500-11-56F	56	56	2208-2056A
500-11-58F	58	58	2208-2058A
500-11-60G	60	60	2208-2060A
500-11-62G	62	62	2208-2062A
500-11-64H	64	64	2208-2064A
500-11-66H	66	66	2208-2066A
500-11-68I	68	68	2208-2068A
500-11-70I	70	70	2208-2070A
500-11-72J	72	72	2208-2072A
500-11-74J	74	74	2208-2074A

### Trident Hemispherical HA Cluster Shells

CATALOG NUMBER	SHELL SIZE (mm)	RIM DIAMETER (mm)	WINDOW TRIAL CATALOG NO.
502-11-46C	46	46	2208-2046A
502-11-48D	48	48	2208-2048A
502-11-50D	50	50	2208-2050A
502-11-52E	52	52	2208-2052A
502-11-54E	54	54	2208-2054A
502-11-56F	56	56	2208-2056A
502-11-58F	58	58	2208-2058A
502-11-60G	60	60	2208-2060A
502-11-62G	62	62	2208-2062A
502-11-64H	64	64	2208-2064A
502-11-66H	66	66	2208-2066A
502-11-68I	68	68	2208-2068A
502-11-70I	70	70	2208-2070A
502-11-72J	72	72	2208-2072A
502-11-74J	74	74	2208-2074A



### Trident PSL HA Solid Back Shells

CATALOG NUMBER	SHELL SIZE (mm)	RIM DIAMETER (mm)	WINDOW TRIAL CATALOG NO.
540-11-44C	44	45.8	2208-2044A
540-11-46D	46	47.8	2208-2046A
540-11-48D	48	49.8	2208-2048A
540-11-50E	50	51.8	2208-2050A
540-11-52E	52	53.8	2208-2052A
540-11-54F	54	55.8	2208-2054A
540-11-56F	56	57.8	2208-2056A
540-11-58G	58	59.8	2208-2058A
540-11-60G	60	61.8	2208-2060A
540-11-62H	62	63.8	2208-2062A
540-11-64H	64	65.8	2208-2064A
540-11-66I	66	67.8	2208-2066A
540-11-68I	68	69.8	2208-2068A
540-11-70J	70	71.8	2208-2070A
540-11-72J	72	73.8	2208-2072A



### Trident PSL HA Cluster Shells

CATALOG NUMBER	SHELL SIZE (mm)	RIM DIAMETER (mm)	WINDOW TRIAL CATALOG NO.
542-11-44C	44	45.8	2208-2044A
542-11-46D	46	47.8	2208-2046A
542-11-48D	48	49.8	2208-2048A
542-11-50E	50	51.8	2208-2050A
542-11-52E	52	53.8	2208-2052A
542-11-54F	54	55.8	2208-2054A
542-11-56F	56	57.8	2208-2056A
542-11-58G	58	59.8	2208-2058A
542-11-60G	60	61.8	2208-2060A
542-11-62H	62	63.8	2208-2062A
542-11-64H	64	65.8	2208-2064A
542-11-66I	66	67.8	2208-2066A
542-11-68I	68	69.8	2208-2068A
542-11-70J	70	71.8	2208-2070A
542-11-72J	72	73.8	2208-2072A

### Trident Window Trial/Trial Liner Sizing

WINDOW TRIAL CATALOG NUMBER	TRIDENT WINDOW TRIAL OD (mm)	TRIAL LINER ALPHA CODE
2208-2044A	44	C
2208-2046A	46	D
2208-2048A	48	D
2208-2050A	50	E
2208-2052A	52	E
2208-2054A	54	F
2208-2056A	56	F
2208-2058A	58	G
2208-2060A	60	G
2208-2062A	62	H
2208-2064A	64	H
2208-2066A	66	I
2208-2068A	68	I
2208-2070A	70	J
2208-2072A	72	J

### X-ray Templates

Titanium Solid Back and Cluster Hole Acetabular System	LTEM102
Titanium Multi-Hole Acetabular System	LTEM89
Trident PSL Acetabular System	LTEM59
Trident Hemispherical Acetabular System	LTEM60





**Reconstructive**

---

Hips  
Knees  
Trauma & Extremities  
Joint Preservation  
Orthobiologics

**Medical & Surgical**

---

Power Tools & Surgical Accessories  
Image Guided Navigation  
Endoscopy & Arthroscopy  
Integrated Communications  
Beds, Stretchers & EMS  
Sustainability Solutions

**Neurotechnology & Spine**

---

Craniomaxillofacial  
Interventional Spine  
Neurosurgical, Spine & ENT  
Neurovascular  
Spinal Implants

325 Corporate Drive  
Mahwah, NJ 07430  
t: 201 831 5000

[www.stryker.com](http://www.stryker.com)

A surgeon must always rely on his or her own professional clinical judgment when deciding whether to use a particular product when treating a particular patient. Stryker does not dispense medical advice and recommends that surgeons be trained in the use of any particular product before using it in surgery.

The information presented is intended to demonstrate the breadth of Stryker product offerings. A surgeon must always refer to the package insert, product label and/or instructions for use before using any Stryker product. Products may not be available in all markets because product availability is subject to the regulatory and/or medical practices in individual markets. Please contact your Stryker representative if you have questions about the availability of Stryker products in your area.

Stryker Corporation or its divisions or other corporate affiliated entities own, use or have applied for the following trademarks or service marks: ADM, CuttingEdge, LFIT, MDM, Stryker, Stryker Orthopaedics, Trident, Tritanium, V40, X3. All other trademarks are trademarks of their respective owners or holders.

BIOLOX delta is a registered trademark of Ceramtec Ag.

Literature Number: LSP73 Rev. 3

Copyright © 2013 Stryker  
Printed in USA

